

Instruction Manual

omegon

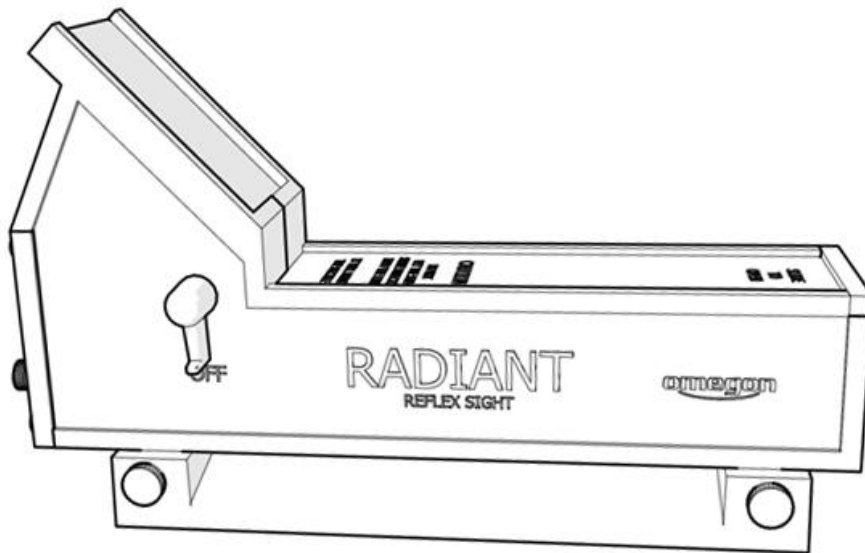

Omegon® Radiant Finder with base

English Version 07.2020 Rev. A, Art.-Nr. 58247

The Omegon® Radiant Finder with base

Congratulations on the purchase of the Omegon® Radiant finder with base. With this finder, finding astronomy objects on the night sky is quick and easy. Three red circles are projected on the optical window allowing to super-impose these circles to the night sky. The brightness adjustment allows locating even the dimmest objects.

1. Knowing your Radiant.

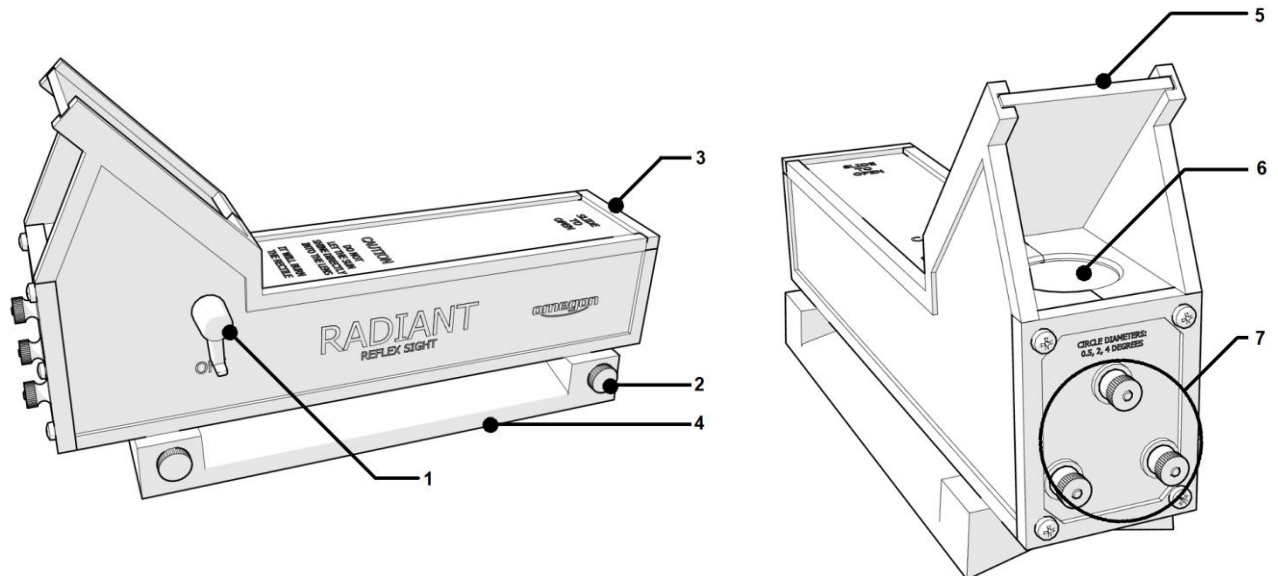

1. On/Off and brightness button;
2. Thumbscrew (two units) to fix Radiant to its plastic base;
3. Lid for the battery compartment;
4. Plastic base;
5. Glass window where the reticule is projected;
6. Condenser lens;
7. Alignment thumbscrews.

2. How to fix Radiant to a telescope? Larger telescopes usually offer a larger surface for fixing the Radiant's plastic base (#4). Ensure your telescope provides at least 180mm in length and 100mm in width of free space. Find a suitable position to place the finder to the telescope's tube. The double side tape included on the plastic base (#4) is very strong, and once the plastic base has been fixed to the tube, it will be very hard to remove it.

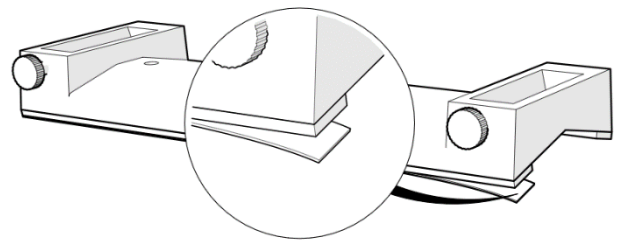

Remove the plastic base (#4) from the assembly and carefully peel the protective plastic from the double side tape. Paste it to the previously assigned position on the telescope. Please make sure that the base is as parallel as possible, to the telescope tube (pointing in the same direction).

If you are right-handed, we recommend pasting the base so that the fixing thumbscrews (#2) are to your right.

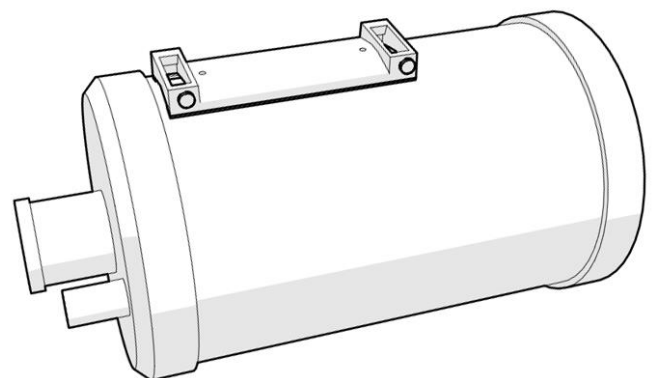

3. Placing the batteries (not supplied). Slide off the lid for the battery compartment (#3) to expose the battery compartment. Remove the battery compartment and place 2xAA batteries (not included). Pay attention to the correct polarity.

4. Testing. Place the finder and fix it to its plastic base (that has been previously fixed to the telescope). Use the two thumbscrews (#2) to fix it tightly to the base (#4).

Turn ON the finder by rotating the ON/OFF button (#1). A loud “click” is heard when switching to ON or OFF. Rotate it to its maximum position to obtain the maximum brightness of the circles.

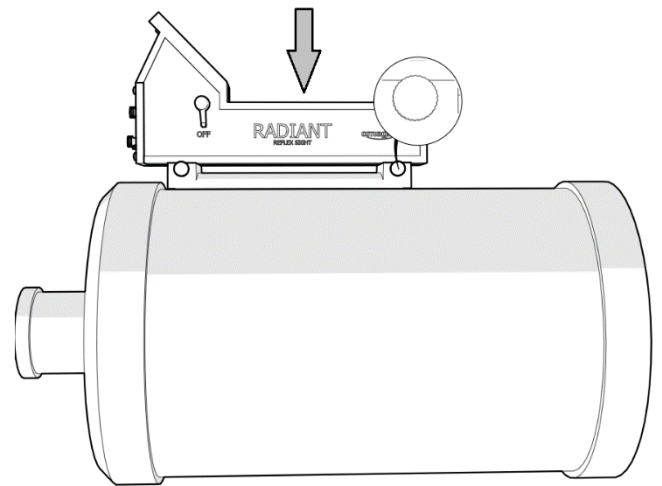

Peek through the glass window where the reticule is projected (#5) as shown. Make sure you see three red circles.

The red circles are ONLY visible from one direction (as shown) and in a dark environment! These kinds of finders cannot be used during the day!

It is important to mention that the circles will only be visible in a dark environment. We recommend conducting this test indoors in a low illuminated room. Use the ON/OFF and brightness button (#1) to adjust and familiarise brightness and how the finder works.

5. How do the circles look like?



There are three circles with different angular sizes of 4, 2 and 0.5deg. They are important to determine object's relative size and angular distance.

The reticules are used to locate objects in the night sky, but before that it is necessary to align the finder with the telescope.

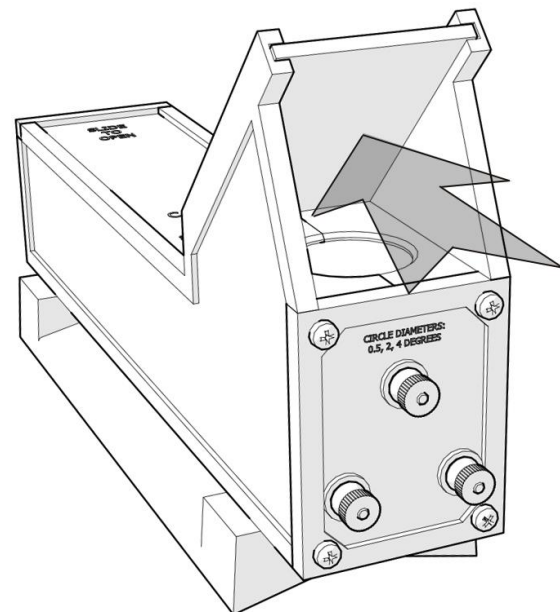

6. How to align it to the telescope?

STEP 1.

As mentioned previously, this alignment procedure should be done in a dark environment or during the night. Only this way can one see the red reticule. Turn ON the finder and set it to its maximum brightness (use new batteries).

STEP 2

Select a low power eyepiece. Point the telescope to a distant land object, easy to recognize, like a church tower. Centre its pinnacle or a distinct feature into the eyepiece's centre of view.

STEP 3

Peek through the glass window where the reticule is projected (#5) and compare the reticule's position to that of the telescope (some telescope configurations and designs may invert or mirror the seen image). We want to make sure that the smallest circle is centred to the previous selected object as seen through the telescope.

Initially this circle should be way off, and just by chance will be centred to the object. To centre it, use the three alignment thumbscrews (#7). Each will displace the red reticules in distinct trajectories 120 degrees apart. Get used to see which direction each one moves. Adjust as necessary. As soon as the circles match the object as seen through telescope - alignment is successful. Repeat if necessary for each observing session.

7. Care and maintenance.

- To save power reduce the brightness to the minimum necessary. Make sure to turn OFF completely after the observation session is over; it is very common to leave the brightness to a minimum and then when realize that it has been on for a while;
- The glass window is prone to condensation. Use a gentle heat source such a portable hair dryer if necessary;
- Clean optical surfaces such as the condenser lens (#6) and Glass window (#5) with a microfiber cloth. Do not apply pressure and make sure it is free of debris;
- Discard used batteries according to local laws and environmental rules;
- Store you Radiant when not in use in it's original box.

And very important!

DO NOT POINT THE FINDER TO THE SUN or its vicinity!
Permanent damage will occur!