

## INSTRUCTION MANUAL

# Orion® Monster Parallelogram Binocular Mount

#5752



 **ORION**  
TELESCOPES & BINOCULARS

*Providing Exceptional Consumer Optical Products Since 1975*

*Customer Support:*

[www.OrionTelescopes.com/contactus](http://www.OrionTelescopes.com/contactus)

*Corporate Offices:*

89 Hangar Way, Watsonville CA 95076 - USA

Copyright © 2015 Orion Telescopes & Binoculars

All Rights Reserved. No part of this product instruction or any of its contents may be reproduced, copied, modified or adapted, without the prior written consent of Orion Telescopes & Binoculars.

Congratulations on your purchase of the Orion Monster Parallelogram Binocular Mount. This heavy-duty parallelogram binocular mount is designed to allow comfortable use of binoculars up to 100mm in aperture or weighing up to 15 lbs. for astronomical or terrestrial viewing. The mount greatly reduces arm fatigue and neck strain compared to using binoculars by hand or with a standard photographic tripod. It also allows the viewer to stand or sit comfortably under the binoculars while aiming it overhead. The mount enables the binoculars to be raised and lowered while still staying right on a given target, a wonderful feature when two or more people of different heights are observing together. The included heavy-duty stainless steel tripod insures maximum stability and vibration dampening of the binoculars. Small telescopes can also be used; especially short refractors and even some small catadioptric telescopes, making this the most versatile binocular mount of its kind on the market.

## Parts List Figure A.

1. Parallelogram mount body
2. Stainless steel tripod with accessory tray
3. Two 11-lb. counterweights
4. L-bracket
5. Mini dovetail bar
6. Mini dovetail saddle
7. ¼"-20 Socket screw
8. Allen wrenches
9. Nut Key 13/14
10. Handle
11. Base
12. Counterweight shaft
13. PTFE washer (white)
14. Setscrews, 2 large, 1 small
15. Two knobs (not installed)

## 1. Assembly

Start by unpacking the mount, the tripod and all the included parts and identify them from the parts list (**Fig. A**). The mount comes partially disassembled for shipping and requires some assembly before first use.

1.1. Place the white PTFE washer onto the mount shaft as shown in **Fig. 1.1**. Then insert the shaft into the base (part 11).

1.2. Install the two large setscrews and hand knob into base (**Fig. 1.2**). Use the 4mm Allen wrench to thread in the set-

**WARNING: Never look directly at the Sun with the naked eye or with an optical instrument – unless you have a proper solar filter installed over the front of the instrument! Otherwise, permanent, irreversible eye damage may result.**

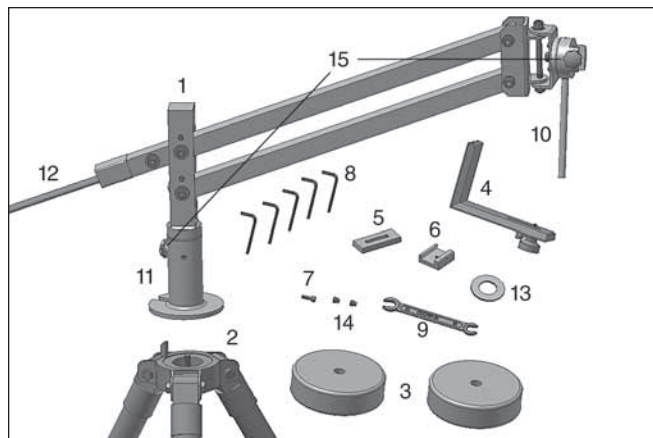

**Fig. A.** Parts List

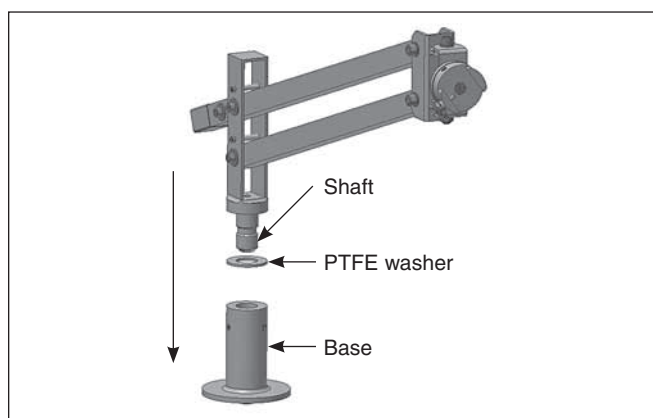

**Fig. 1.1.**

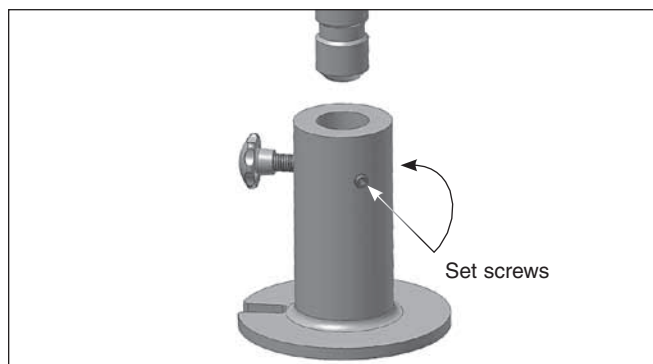

**Fig. 1.2.**

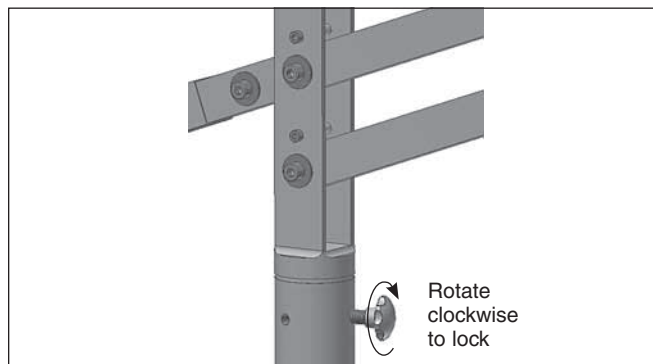

**Fig. 1.3.**

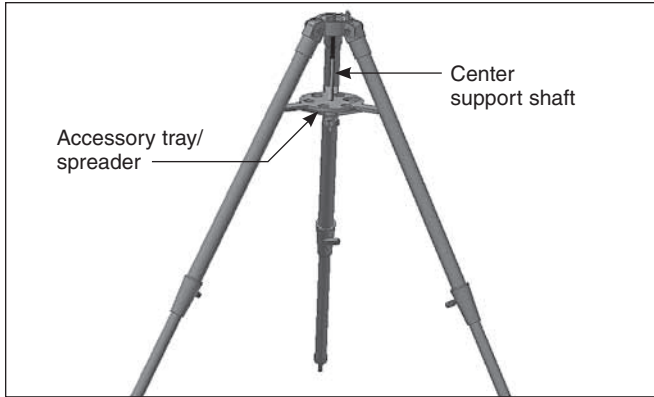

**Fig. 1.4.**

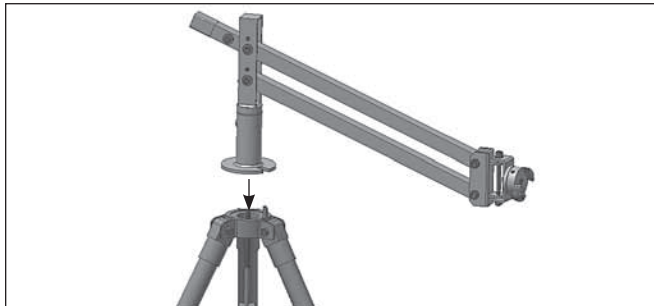

**Fig. 1.5.**

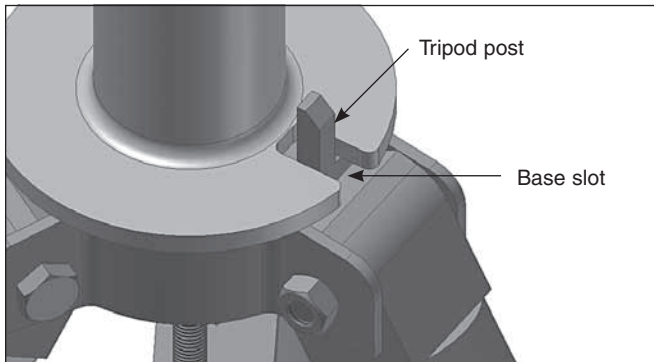
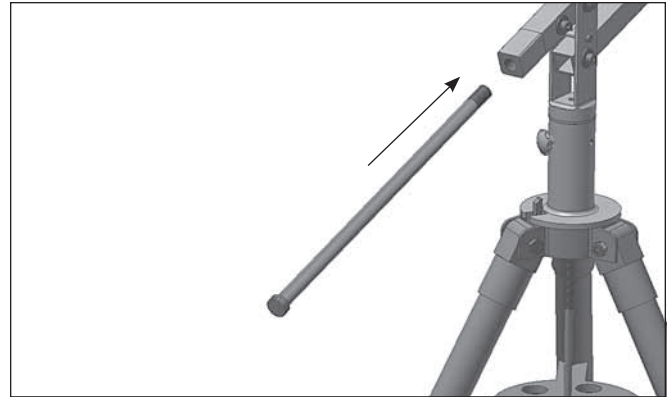

**Fig. 1.6.**

screws. Keep the setscrews and knob bolt from protruding into the center cylinder of the base, to allow the shaft to be inserted fully. Once inserted, make sure the two set screws are threaded back in until they lightly touch the shaft. They act as retaining screws to insure that the parallelogram body does not detach from the base.

1.3. Rotate the parallelogram in relation to the base. If desired you can “lock” the azimuth position of the parallelogram by tightening the hand knob (**Fig. 1.3**). The hand knob acts more like a soft brake than a lock and does not completely prevent the rotation of the parallelogram mount.

1.4. Assemble the SkyView Pro tripod (use the on-line instruction manual for the SkyView Pro EQ mount if necessary). Make sure to install the accessory tray/spreader on the center support shaft of the tripod (**Fig. 1.4**) to stabilize the legs.



**Fig. 1.7.**

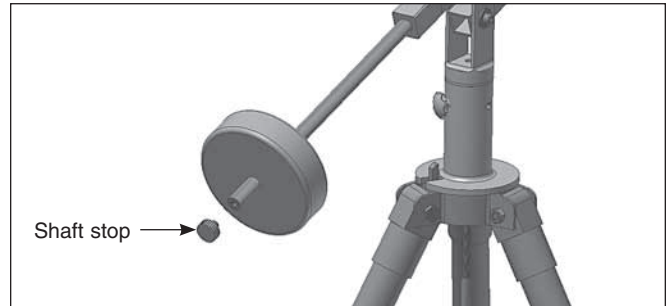

**Fig. 1.8.**

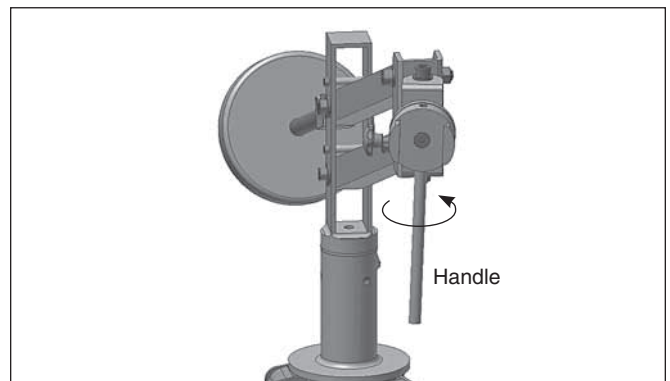

**Fig. 1.9.**

1.5. Place the pre-assembled parallelogram and base on the top of the tripod (**Fig. 1.5**) and securely fasten the hand knob on the upper part of the center support shaft. Make sure that the base slot aligns with the vertical post on the top surface of the tripod (**Fig. 1.6**).

1.7. Insert the counterweight shaft (part 12) into the threaded hole in the end of the parallelogram arm and rotate the shaft clockwise until it is tight (**Fig. 1.7**).

1.8. Install one 11-lb. counterweight on the shaft. Use the counterweight’s lock knob to position the counterweight near the end of the shaft, for now. Then thread the shaft stop safety knob onto the end of the shaft to prevent the counterweight from accidentally slipping off (**Fig. 1.8**).

1.9. Insert the handle (part 10) where shown in **Fig. 1.9** and thread it in until tight.

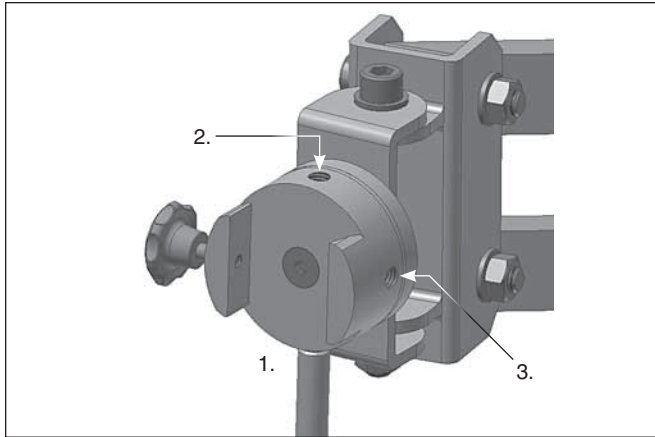

**Fig. 1.10.**



**Fig. 2.1.**

1.10. There are three possible positions for the handle, as shown in **Fig. 1.10**, which shows it in position 1.

## 2. Installing a Telescope or Binoculars

**2.1.** The Monster parallelgram mount can be used with small telescopes or spotting scopes equipped with a standard dovetail bar. Many Orion telescopes use this kind of dovetail to attach the optical tube to the mount. Set the handle to position 3 (opposite position to the dovetail locking hand knob).

**2.2.** For binoculars use the supplied L-bracket (part 4). Install the included hand knob to securely fasten the L-bracket as shown in **Fig. 2.2**.

**2.3.** The L-bracket's captive 1/4"-20 threaded post is compatible with the female 1/4"-20 socket of a digital camera or binocular adapter.

**2.4.** Place the binoculars (in this example, the Orion Giant View 25x100 binoculars) on the L-bracket with the binocular adapter aligned with the 1/4"-20 threaded post. Turn the

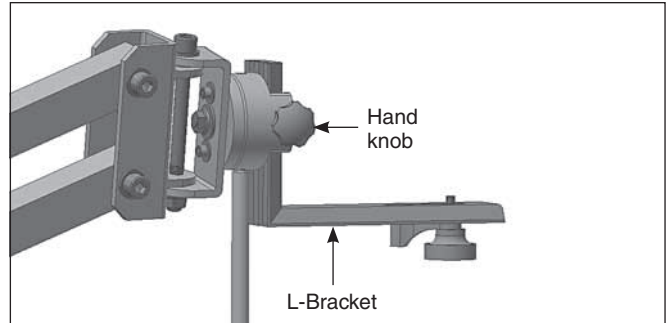

**Fig. 2.2.**

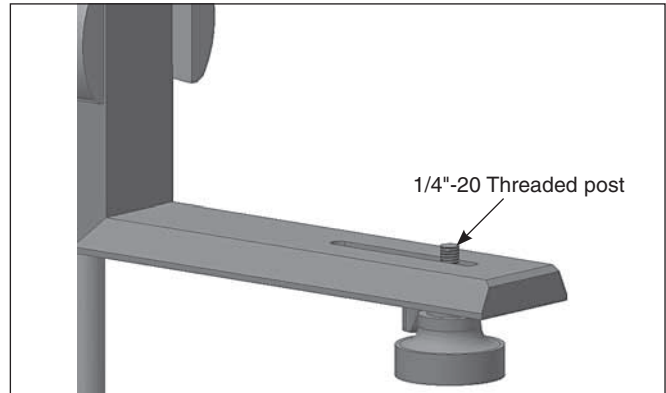

**Fig. 2.3.**

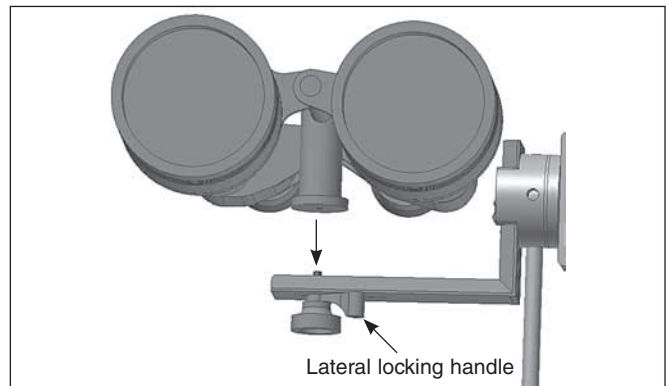

**Fig. 2.4.**

L-bracket knob until you feel a firm grip. Then use the lateral locking handle (**Fig. 2.4**) for final tightening to insure that the binocular is securely fastened.

**2.5.** For other binocular models (usually with apertures smaller than 100mm) a tripod L-adapter (sold separately) is required to mount them.

## 3. Balance

In order to properly observe with binoculars or a small telescope mounted on the Monster Parallelgram, the weight of the instrument must be counterbalanced. Start by sliding the

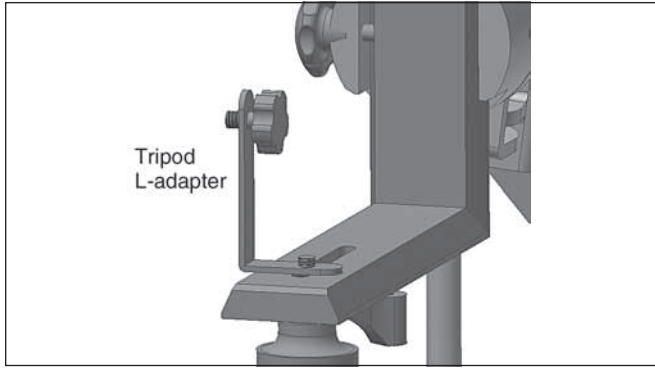

**Fig. 2.5.**

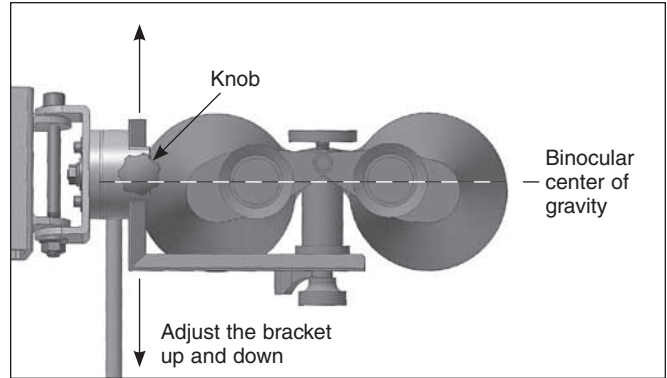

**Fig. 3.3.**

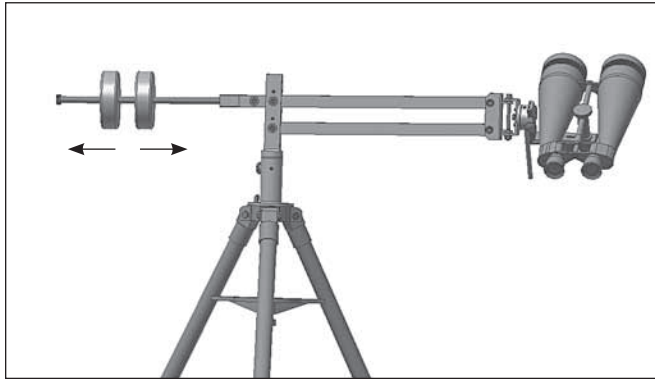

**Fig. 3.1**

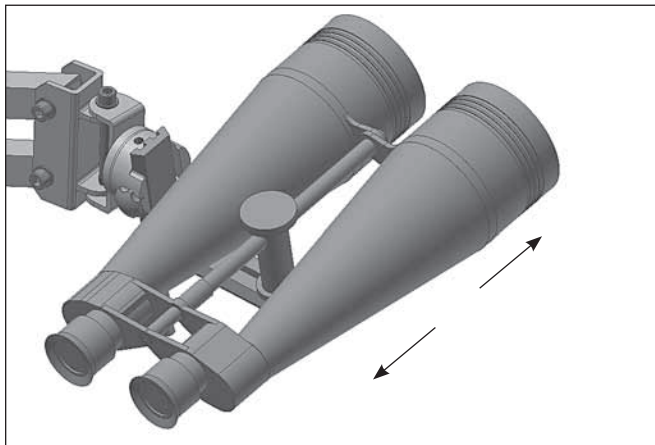
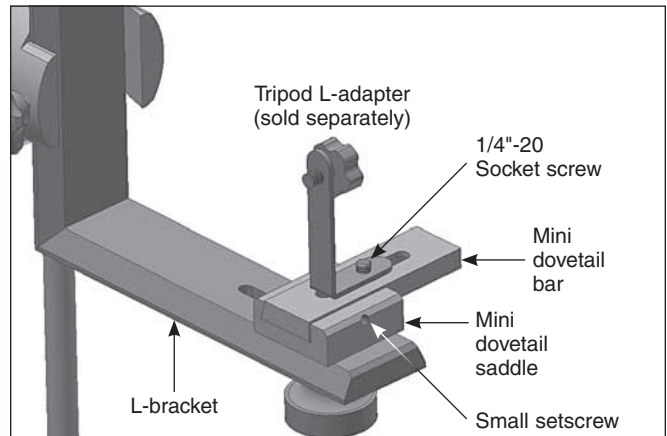

**Fig. 3.2.**

counterweight(s) on the counterweight shaft – whether one or two counterweights will be needed depends on the weight of the binoculars – until the mount is balanced in the horizontal position (**Fig. 3.1**), then tighten the counterweight lock knob(s).

Now you must balance the binoculars on the L-bracket itself, if possible. Move the binoculars back and forth (**Fig. 3.2**) until you reach a balance point, i.e., the binoculars do not rotate forward or back on the L-bracket.

One final adjustment is still required. For optimum balance the binoculars' center of gravity must also be adjusted so that it is



**Fig. 3.4.**

aligned with the hand-knob on the L-bracket's dovetail saddle, as shown in **Fig. 3.3**.

#### Using the Mini-Dovetail

Binoculars that are not equipped with an integrated, sliding binocular mounting adapter as in the example above do not provide any way of adjusting balance on the L-bracket. So we have included a mini-dovetail system that makes such balance adjustment possible. Place the mini-dovetail saddle (part 6) on the L-bracket as in **Fig. 3.4** and secure it with the L-bracket's ¼"-20 knob and lateral locking handle.

Attach a tripod L-adapter (sold separately) on the mini dovetail bar (part 5) as shown in **Fig. 3.4** with the included ¼"-20 socket screw and the 5.5mm Allen wrench. Then slide the mini-dovetail bar into the saddle and lock it tightly with the small setscrew and corresponding Allen wrench.

Then attach your binoculars to the tripod L-adapter. With the binoculars oriented parallel to the ground, slightly loosen the setscrew while maintaining hold of the binocular with the other hand and slide the dovetail bar forward or back until the binoculars are balanced on the L-bracket – again, without letting go of the binoculars! Then retighten the locking setscrew to secure the mini dovetail bar at that position.

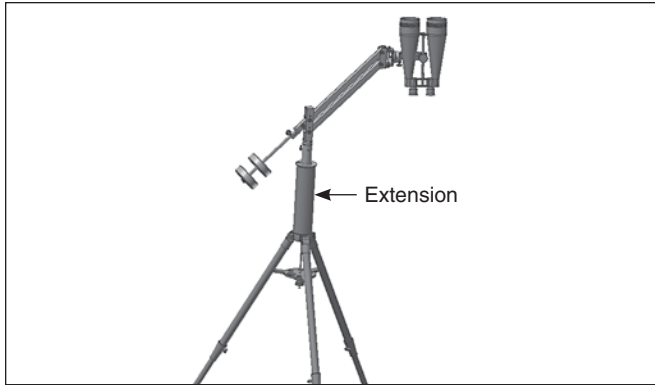

**Fig. 4.1**

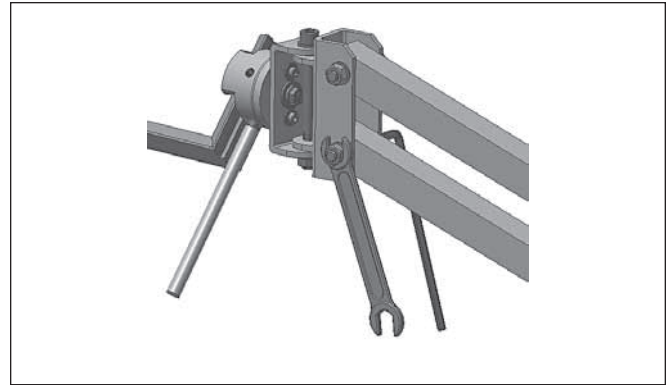

**Fig. 5.2.**

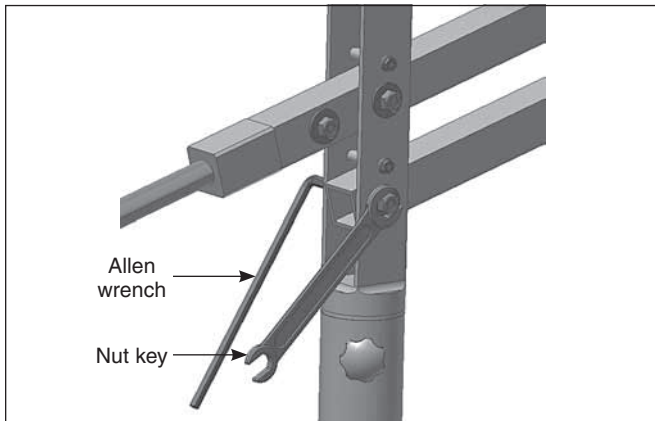

**Fig. 5.1.**

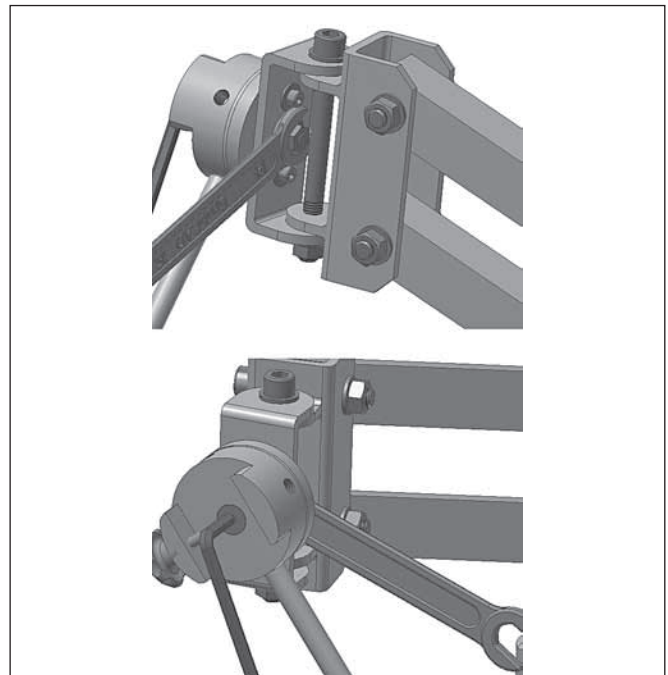

**Fig. 5.3.**

## 4. Pointing to Zenith

The purpose of the Monster Parallelogram mount is to be able to use binoculars, especially big binoculars, comfortably. Tall users, however, may wish to raise the binoculars higher than the parallelogram mount permits, especially if observing while standing and aiming toward the zenith (straight overhead). For them, we recommend using the Orion SkyView Pro Telescope Mount Extension (not included), which adds an additional 16" of height to the system (**Fig. 4.1**). The extension also adds more stability to the mount by increasing its total mass. If you are taller than 6 feet we strongly recommend that you add this optional extension.

## 5. Maintenance and Care

The Monster Parallelogram mount has been carefully manufactured, assembled, and packed. Great care was taken at the factory to insure that all components work as intended and were adjusted for smooth operation. Some play between parts is acceptable. If, however, you find that the movement of the Parallelogram in any of the axes of motion is too stiff or, conversely, too free (loose), then you can make adjustments at those points accordingly.

Having the proper tension on the socket screws that hold these parts in place is important for smooth movement and proper performance of the Parallelogram mount. Areas that can be adjusted are shown in **Figs. 5.1 – 5.3**. We have included a 13/14 nut key and some Allen wrenches for this purpose.

Adjust pressure/friction on both ends of the square parallel tubes using the supplied nut key and 6mm Allen Wrench (**Figs. 5.1 and 5.2**). The dovetail saddle (**Fig. 5.3**) can also be adjusted if necessary.

The Monster Parallelogram Mount is designed with safety in mind. The two parallel bars of the mount are separated by a gap to prevent fingers from getting crushed. The counterweight safety stop prevents counterweights from slipping off and injuring one's feet. Still, use caution when using the mount, particularly when other people are present and it is dark outside, to prevent the parallelogram arm or the counterweights from inadvertently hitting anyone!



---

## **One-Year Limited Warranty**

This Orion product is warranted against defects in materials or workmanship for a period of one year from the date of purchase. This warranty is for the benefit of the original retail purchaser only. During this warranty period Orion Telescopes & Binoculars will repair or replace, at Orion's option, any warranted instrument that proves to be defective, provided it is returned postage paid. Proof of purchase (such as a copy of the original receipt) is required. This warranty is only valid in the country of purchase.

This warranty does not apply if, in Orion's judgment, the instrument has been abused, mishandled, or modified, nor does it apply to normal wear and tear. This warranty gives you specific legal rights. It is not intended to remove or restrict your other legal rights under applicable local consumer law; your state or national statutory consumer rights governing the sale of consumer goods remain fully applicable.

For further warranty information, please visit [www.OrionTelescopes.com/warranty](http://www.OrionTelescopes.com/warranty).

Orion Telescopes & Binoculars

Corporate Offices: 89 Hangar Way, Watsonville CA 95076 - USA

Customer Support: [www.OrionTelescopes.com/contactus](http://www.OrionTelescopes.com/contactus)

Copyright © 2015 Orion Telescopes & Binoculars

All Rights Reserved. No part of this product instruction or any of its contents may be reproduced, copied, modified or adapted, without the prior written consent of Orion Telescopes & Binoculars.