

# Orion SkyQuest™ XX14i IntelliScope Truss Tube Dobsonian

#10024



 **ORION**  
**TELESCOPES & BINOCULARS**  
*Providing Exceptional Consumer Optical Products Since 1975*

*Customer Support:*  
[www.OrionTelescopes.com/contactus](http://www.OrionTelescopes.com/contactus)  
*Corporate Offices:*  
89 Hangar Way, Watsonville CA 95076 - USA



**Figure 1.** The SkyQuest XX14i IntelliScope Truss Tube Dobsonian

---

*Congratulations on your purchase of an Orion® SkyQuest™ XX14i IntelliScope® Truss Tube Dobsonian.* It's a deep-sky observer's dream telescope, offering jumbo 14" parabolic optics; an Orion-engineered collapsible base outfitted with IntelliScope object locating technology; and a sturdy truss tube design that easily disassembles into compact, portable components. This high-performance, large-aperture astronomical instrument is designed to provide dazzling views of celestial objects, yet also be unusually transportable and easy to use.

With the IntelliScope Computerized Object Locator, you'll be able to locate and view thousands of celestial objects with the push of a few buttons on the illuminated hand controller. Searching for objects is a thing of the past, as the IntelliScope's high-resolution digital encoders find them for you – in seconds! Ebony Star on Virgin PTFE/UHMW azimuth bearings and large 8" diameter adjustable-tension altitude bearings make slewing the telescope and keeping objects centered in the eyepiece, i.e., tracking them, smooth and easy. Deluxe features such as a 2" dual-speed Crayford focuser and enhanced reflectivity (94%) mirror coatings, as well as great accessories like a 2" DeepView eyepiece and 9x50mm finder scope, provide everything you need to enjoy your exploration of the night sky's many treasures.

Please read these instructions thoroughly before beginning assembly and subsequent use of the telescope.

## Table Contents

1. Unpacking . . . . .	3
2. Assembly . . . . .	8
3. Aligning (Collimating) the Optical System. . . . .	20
4. Using Your Telescope . . . . .	23
5. Astronomical Observing . . . . .	27
6. Care and Maintenance . . . . .	31
7. Specifications . . . . .	33

## 1. Unpacking

The telescope is packed in four shipping boxes, as detailed below. We recommend keeping the original packaging. In the event that the telescope needs to be shipped to another location, or returned to Orion for warranty repair, having the proper packaging will help insure that your telescope will survive the journey intact.

Referring to **Figures 2 through 6**, make sure all the parts in the Parts List are present. The parts are listed by the box they should arrive in, but some of the parts may be in different boxes than indicated. Be sure to check all boxes carefully, as some parts are very small. If anything appears to be missing or broken, immediately call Orion Customer Support (800-676-1343) or email [support@telescope.com](mailto:support@telescope.com) for assistance.

**WARNING:** *Never look at the sun with your telescope (or even with just your eyes) without a professionally made solar filter. Permanent eye damage or blindness could result. Young children should use this telescope only with adult supervision.*

*Avoid using the type of solar filter that screws into an eyepiece. They are susceptible to cracking under the intense heat that builds up near the focus point, and could cause severe retinal damage. Use only the type of solar filter that covers the front of the telescope. Also, be sure to leave the cover caps on the finder scope when solar observing. Better yet, remove the finder scope altogether when viewing the sun.*



**Figure 2.** The parts in the box containing the optical tube and accessories.



**Figure 3.** The parts contained in the IntelliScope Object Locator box.

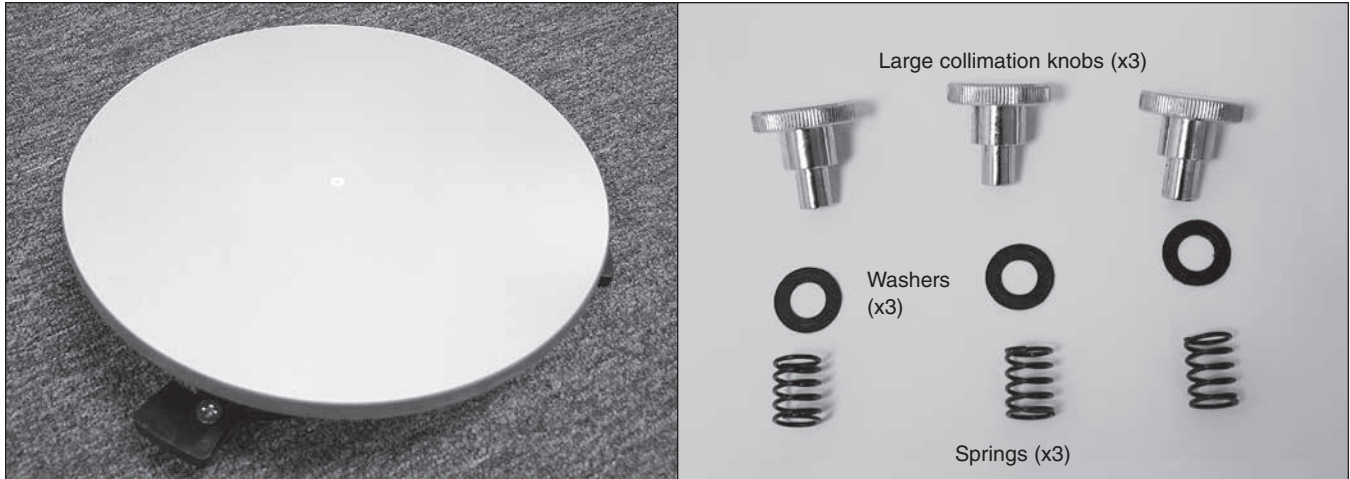
## Parts List

### Box #1: Optical Tube Assembly and Accessories (refer to Figure 2)

Qty.	Description
1	Lower optical tube section
1	Upper optical tube section
2	Dust covers
1	IntelliScope Object Locator kit (see Box #1A at right for list of parts)
1	35mm Deep View eyepiece, 2" barrel diameter
1	10mm Sirius Plössl eyepiece, 1.25" barrel diameter
1	9x50 finder scope
1	Finder scope bracket with O-ring
1	Collimation cap
3	Hex keys (2mm, 2.5mm, 4mm)
6	Counterweights, 2.3 lbs. (1.0 kg)
1	XX14i Instruction Manual (not shown)

### Box #1A: IntelliScope Object Locator Kit (refer to Figure 3)

Qty.	Description
1	IntelliScope Object Locator (hand controller)
1	Altitude encoder assembly (board and disk)
1	Azimuth encoder board
1	Encoder connector board
1	Azimuth encoder disk
1	Controller cable (coil cable)
1	Azimuth encoder cable (shorter)
1	Altitude encoder cable (longer)
1	Azimuth encoder spacer washer, thin (1/4" outer dia., 0.015" thick)
4	Encoder connector board washers (3/8" outer dia.)
2	Altitude encoder nylon spacer washers (1/4" outer dia., white)
6	Wire clips
1	9V Battery
1	Hook-and-loop adhesive strips
1	Altitude encoder bumper
1	Altitude retaining knob spacer (3/16" thick, 1/2" dia., white)
1	Computerized Object Locator Instruction Manual



**Figure 4.** The parts in the box containing the primary mirror and mirror cell.

**Box #2: Primary Mirror and Cell** (refer to Figure 4)

*Qty. Description*

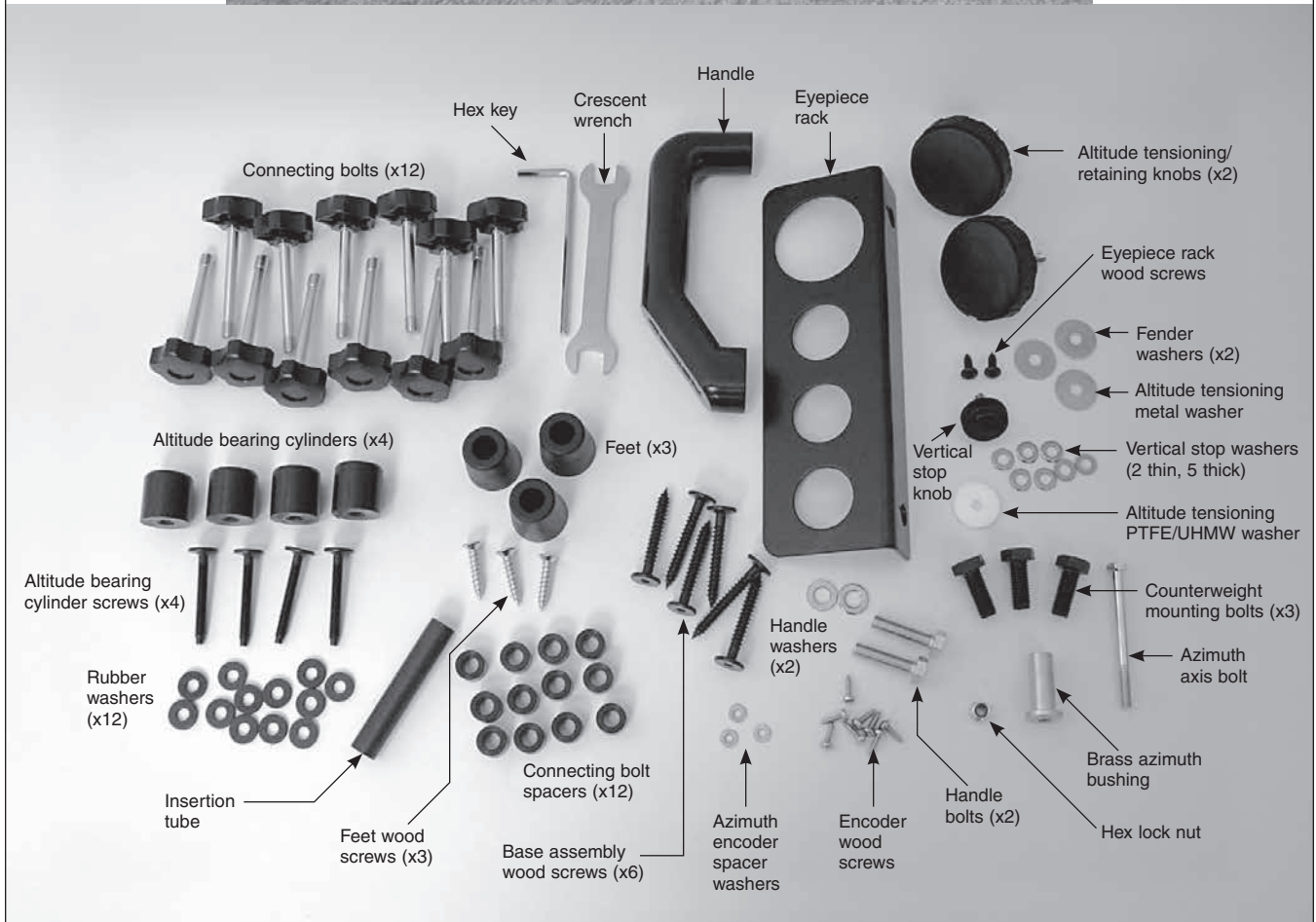
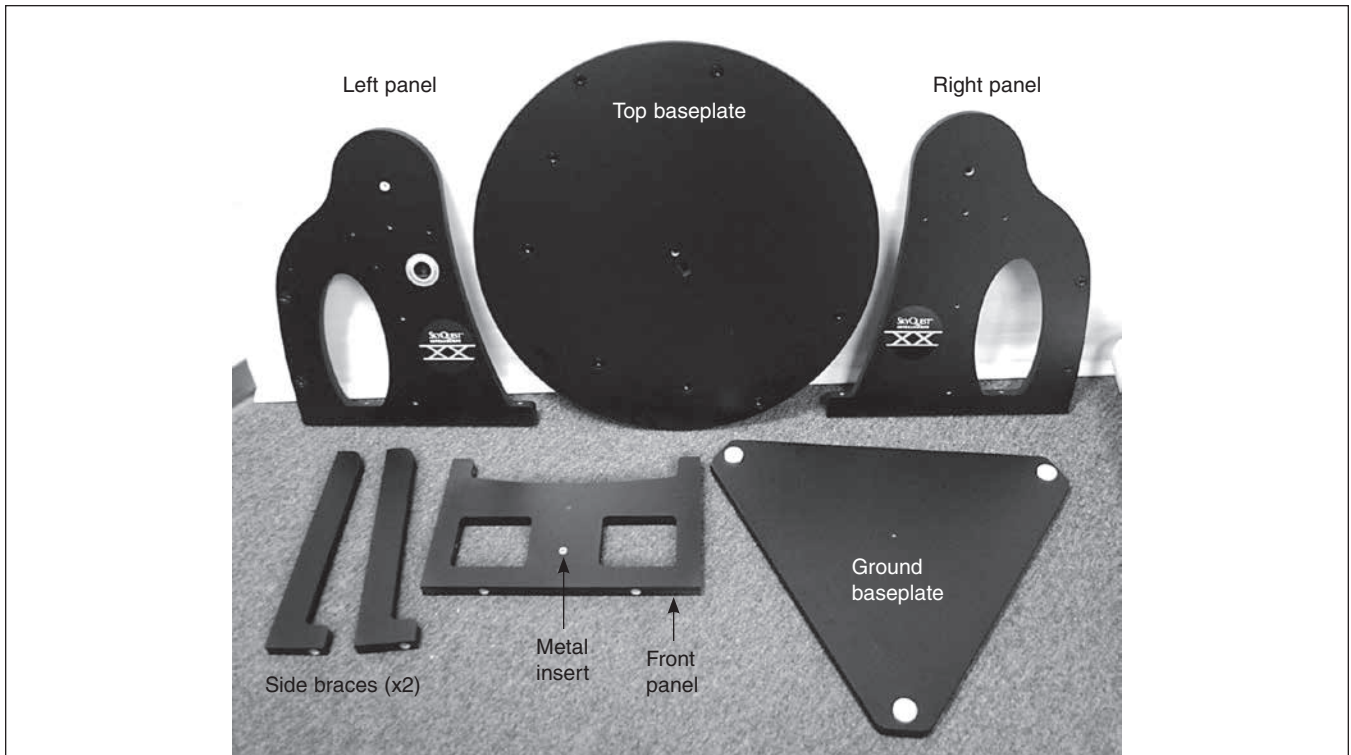
- 1 Primary mirror
- 1 Mirror cell
- 3 Collimation knobs
- 3 Nylon washers (3/4" outer dia.)
- 3 Springs

**Box #3: Dobsonian Base** (refer to Figure 5)

*Qty. Description*

- 1 Left panel
- 1 Right panel
- 1 Front panel
- 1 Top baseplate
- 1 Ground baseplate
- 2 Side braces
- 6 Base assembly wood screws (2" long, black)
- 12 Captive base connecting bolts with hand knobs
- 1 Handle
- 2 Handle screws (hex head, 1.5" long)
- 2 Handle washers (5/8" outer dia.)
- 1 Crescent wrench
- 1 Hex key (size 4mm)
- 3 Plastic feet
- 3 Feet wood screws (1" long)

- 8 Encoder wood screws (1/2" long)
- 12 Rubber washers
- 12 Spacers for connecting bolts (10mm long, 15mm dia.)
- 1 Insertion tube for rubber washers (~3" long)
- 3 Counterweight attachment bolts (hex head, 1-3/8" long, black)
- 1 Brass azimuth bushing
- 1 Azimuth axis bolt (hex head, 2.75" long)
- 2 Fender washers (1" outer dia.)
- 1 Hex lock nut
- 4 Altitude bearing cylinders
- 4 Altitude bearing cylinder screws (1.75" long, black)
- 1 Vertical stop knob
- 5 Vertical stop washers, thick (5/8" outer diameter, 1/16" thick)
- 2 Vertical stop washers, thin (1/2" outer diameter, 1/32" thick)
- 3 Azimuth encoder spacer washers, thick (0.35" outer dia., 0.032" thick)
- 1 Eyepiece rack
- 2 Eyepiece rack wood screws (3/4" long, black)
- 2 Altitude tensioning/retaining knobs
- 1 Tensioning knob PTFE/UHMW washer (1" outer dia., white)
- 1 Tensioning knob metal washer (1" outer dia.)



**Figure 5.** The parts in the box containing the Dobsonian base.



**Figure 6.** The parts in the box containing the truss poles.

**Box #4: Truss poles** (refer to Figure 6)

Qty.	Description
4	Truss pole assemblies (captive pairs)

## 2. Assembly

Now that you have unpacked the boxes and familiarized yourself with all of the parts in front of you, it's time to begin assembly. In addition to the supplied tools, you'll need a Phillips screwdriver, a small piece of duct or masking tape, and two adjustable crescent wrenches. (For base assembly, you can substitute a 10mm crescent wrench for one of the adjustable crescent wrenches, or use a pair of pliers.)

### Assembly of the Dobsonian Base

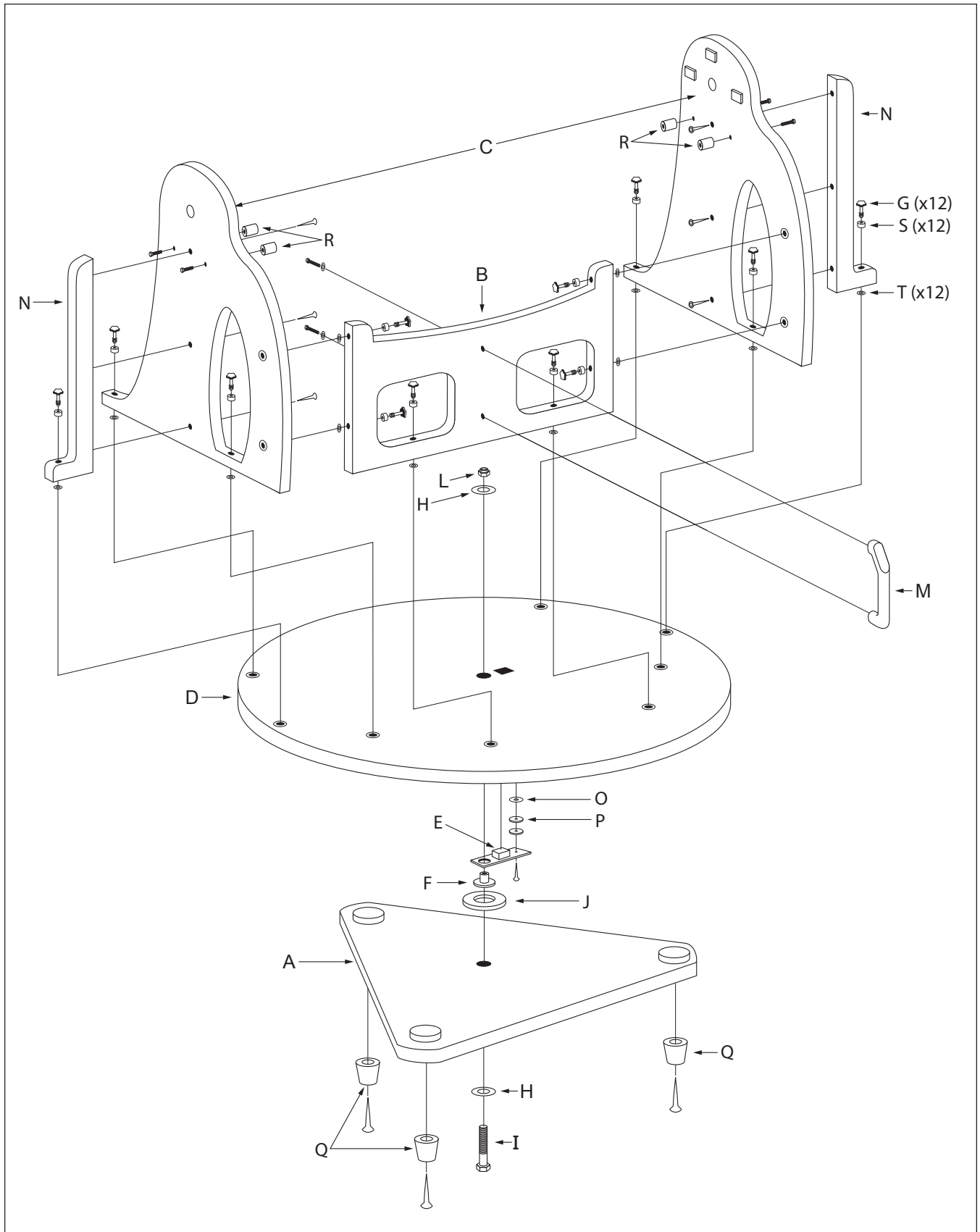
The base of the XX14i was engineered by Orion to allow quick disassembly into several component pieces, to make it more manageable to transport in a standard size vehicle. Assembly is also fast and easy, thanks to a dozen connecting bolts with attached hand knobs. The bolts thread into custom threaded receptacles that are embedded in the adjoining baseplate or side panel. To ensure that you can never lose them, the bolts are held captive in the base when fully loosened, or disconnected. While some owners may never have a need to disassemble the base for transport or storage, others will appreciate this innovative feature, especially if you observe from a remote location and don't happen to drive a large SUV. With its collapsible base and a truss tube design that allows disassembly of the optical tube into smaller sections, this hefty 14" Dob has the portability and manageability of a smaller telescope!

Refer to **Figure 7** during base assembly. When tightening screws, tighten them until firm, but be careful not to strip the holes by over-tightening. If you use an electric screwdriver, do final tightening with a standard screwdriver to avoid stripping.

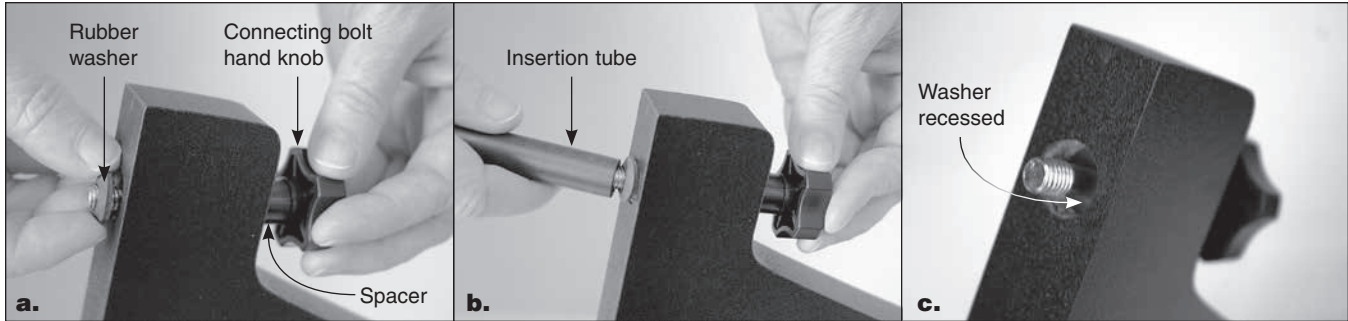
1. With a Phillips screwdriver, screw the feet (Q) into the underside of the ground baseplate (A) using the feet wood screws provided. Insert the screws through the feet and thread them into the predrilled starter holes.
2. Connect the side braces (N) to the side panels (C) using three of the base assembly screws for each panel. The brace should be attached to the outside surface of the side panel, which bears the SkyQuest XX IntelliScope label. The screws go through the holes in the side panels and thread into the starter holes in the side braces. Use the 4mm hex key to firmly tighten the screws.
3. Now you will install the captive connecting bolts (G), each of which is already fitted with a black hand knob. There are 12 connecting bolts altogether; refer to **Figure 7** for locations. Start with the front panel (B), which has through holes for six connecting bolts.

First, slide a spacer (S) onto a collecting bolt (G). Then insert the connecting bolt into the through hole, in the direction indicated in **Figure 7**. Holding the knob with one hand, use your other hand to press a rubber washer (T) over the threaded (protruding) end of the bolt. It will be a tight fit; you may have to work the washer a bit to get it on.





**Figure 7.** Exploded view of the XX14i base.

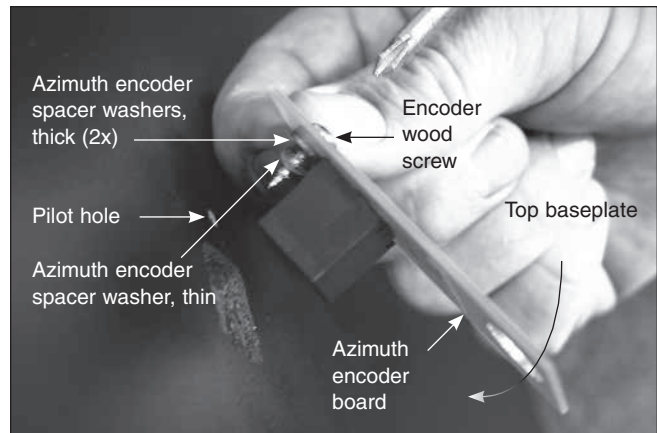


**Figure 8. (a)** Place a rubber washer on the threaded end of the connecting bolt and push it on as far as you can with your fingers. **(b)** Then use the included insertion tube to push the washer past the threads on the bolt and up into the counterbored hole in the wood.

Push the washer up on the bolt as far as you can with your fingers (**Figure 8a**). Then place the insertion tube on the bolt (**Figure 8b**) and use it to push the washer farther up on the bolt, into the counterbored hole in the wood (**Figure 8c**). The washer will keep the bolt captive when it is fully disengaged from the mating part of the base.

Repeat this procedure for the other five connecting bolts to be installed in the front panel, and for the six additional connecting bolts that attach the side panels and side braces to the top baseplate.

4. Now attach the front brace (B) to the two side panels (C) with the four appropriate captive connecting bolts. Use the hand knob to screw each bolt into the threaded metal receptacle recessed in the side panel. The side panels should be oriented so the side braces are facing outward. The front panel should be oriented so that the metal insert (**Figure 5**, top) faces inward. Do not completely tighten the connecting bolts yet.
5. Place the assembled side panel/front panel structure on the top baseplate (D), aligning as best you can the protruding connecting bolts with the holes in the baseplate. The baseplate should be oriented so that the Ebony Star azimuth bearing ring is facing downward. Turn the connecting bolt hand knobs to fasten the side panel/front panel structure to the baseplate.
6. Firmly tighten all 12 connecting bolts installed in steps 4 and 5. Again, do not overtighten to avoid stripping the threads.
7. The azimuth encoder board (E) attaches to the underside of the top baseplate (D). Insert an encoder wood screw through the slotted hole in the azimuth encoder board so that the head of the screw is on the side of the encoder board without the modular connector. Now, place the two thick (P) and one thin (O) azimuth encoder spacer washers on the screw (**Figure 9**). These washers are critical in providing the proper spacing for the assembled azimuth encoder. The two thick azimuth encoder spacer washers are included with the base, but the thin azimuth encoder spacer washer is included with the IntelliScope Object Locator kit.

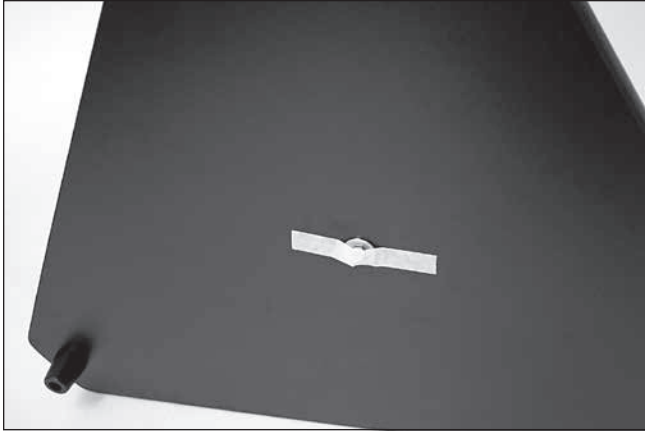


**Figure 9.** To install the azimuth encoder board, insert an encoder board mounting screw through the slotted hole in the board. Then, add two thick and one thin encoder spacing washers onto the screw. Now, insert the modular connector on the encoder board into the square hole in the top baseplate, and thread the screw into the pilot hole using a Phillips head screwdriver.

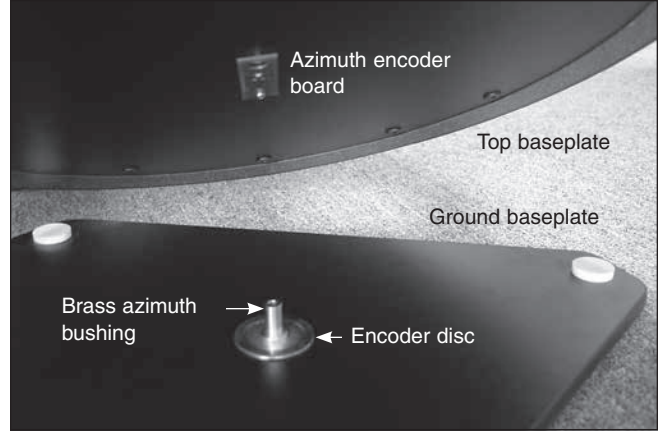
8. Insert the modular jack on the azimuth encoder board (E) into the rectangular cutout in the top baseplate (D) and align the encoder board so the screw lines up with the pre-drilled pilot hole in the baseplate, and the large hole in the encoder board lines up with the central hole in the baseplate (**Figure 9**). Thread the encoder wood screw (with spacer washers attached) into the pilot hole with a Phillips screwdriver and tighten until just tight.

*Note: After the azimuth encoder board is installed to the bottom of the top baseplate, do not rest the baseplate on the ground, or the encoder board could be damaged. At this stage, rest the partially assembled base on its side.*

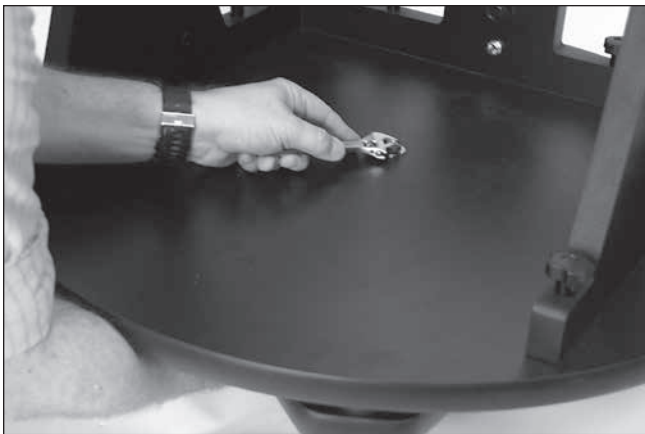
9. Position the ground baseplate (A) so that it is standing on its feet. Place one fender washer (H) onto the azimuth axis bolt (I), then insert the bolt up through the hole in the ground baseplate. Now temporarily place a piece of duct tape, masking tape, or packing tape over the head of the azimuth axis bolt (**Figure 10**). This will keep the bolt from sliding downward as you install the top baseplate, which you will do in step 11.
10. Place the azimuth encoder disk (J), flat side down, over the azimuth axis bolt (I) and onto the ground baseplate (A). Then place the brass azimuth bushing (F) onto the azimuth axis bolt (I) so the wide end of the bushing is closest to the encoder disk (J). Seat the bushing onto the



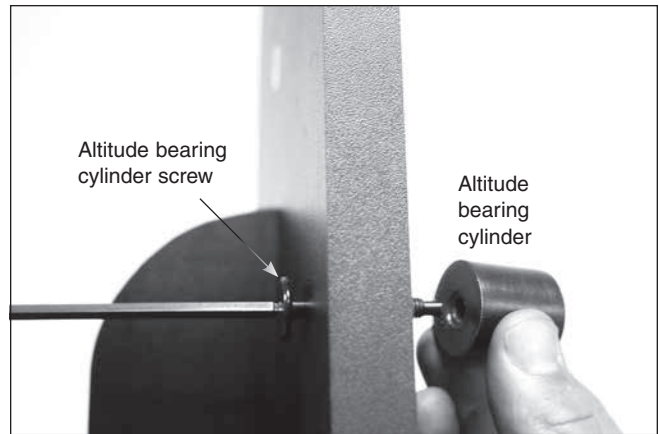
**Figure 10.** Placing a piece of duct, masking, or packing tape over the hex head of the azimuth axis bolt will keep it from dropping downward when you place the top baseplate onto the ground baseplate.



**Figure 11.** Lower the top baseplate onto the ground baseplate. The brass bushing should pass through the center hole in the top baseplate (and the large hole in the azimuth encoder board).



**Figure 12.** To connect the baseplates, tilt them only slightly, as shown. Do not place them on their side. Use one wrench (or pliers) to hold the hex head of the azimuth axis bolt steady while turning the hex lock nut with another wrench.



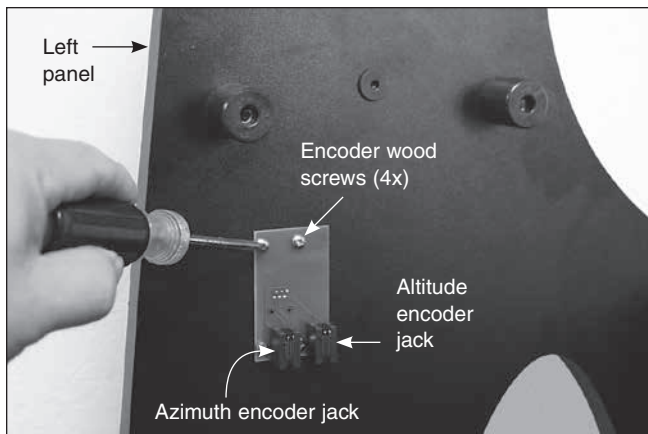
**Figure 13.** Push a bearing cylinder screw through the side panel and thread it into the altitude bearing cylinder. The beveled end of the cylinder should be farthest from the side panel.

encoder disk so the registration feature on the bushing goes into the hole in the encoder disk.

11. Carefully position the top baseplate (D) over the ground baseplate (A) and lower it so the brass azimuth bushing (F) goes through the center hole in the top baseplate (**Figure 11**). When the top baseplate is resting on the ground baseplate, the brass bushing should extend just above the top surface of the top baseplate.
12. Place the remaining fender washer (H) onto the shaft of the azimuth axis bolt (I), then thread the hex lock nut (L) onto the end of the azimuth axis screw and tighten it finger tight, for now.
13. To tighten the hex lock nut (L) onto the azimuth axis bolt (I), tilt the assembled Dobsonian base at a slight angle to lift the ground baseplate off the ground. Remove the tape covering the head of the azimuth axis bolt. Now, with one wrench (or pliers) hold the head of the azimuth axis bolt still while turning the hex lock nut with the other wrench. **Figure 12** shows this being done. Tighten the hex lock

nut just until the top fender washer can no longer move freely, then tighten the hex nut 3/16 to 1/4 turn beyond that. This provides the proper spacing between the azimuth encoder disk and the azimuth encoder board.

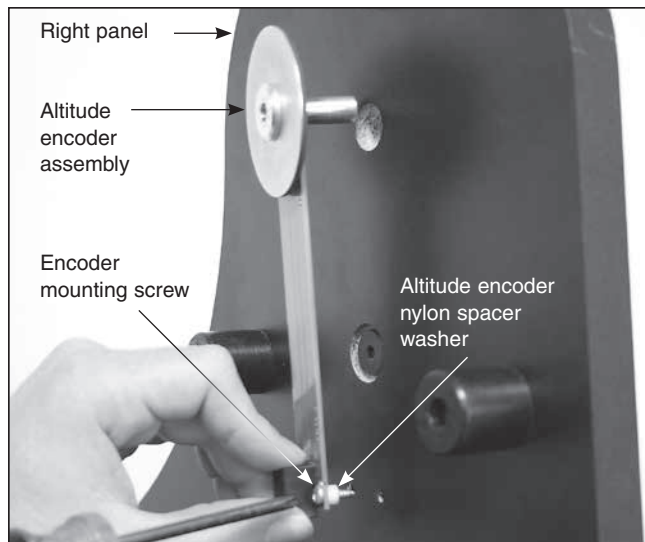
14. Two altitude bearing cylinders (R) connect to the interior surface of each side panel (C). Line up one of the altitude bearing cylinders with one of the two through holes in each side panel. The beveled end of the cylinder should be facing away from the side panel. Push a bearing cylinder screw through the side panel and thread it into the built-in nut in the cylinder with the included 4mm hex key (**Figure 13**). Repeat this for the remaining three bearing cylinders.
15. Attach the encoder connector board to the side panel. Place a wood screw into each of the four holes of the connector board and then an encoder connector board washer onto each screw. Then lightly press the screw tips into the four predrilled holes in the side panel so that the modular jack fits into the rectangular cutout. This is tricky



**Figure 14.** Attach the encoder connector board to the left side panel with four of the encoder wood screws and four encoder connector board washers.

to do, but by lightly pressing the screw tips into the holes, they should “stick” enough so that you can screw them in without one or more of them (and the washers) falling out. Using a small Phillips screwdriver, tighten all four screws (**Figure 14**).

16. The altitude encoder assembly is installed onto the base's right side panel. Below the 5/8" through hole in the right panel, there are two predrilled starter holes in the inward-facing surface. Take two of the encoder wood screws supplied in the IntelliScope kit and push them through the two slotted holes in the bottom of the altitude encoder board. The screw heads should be on the same side as the altitude encoder's modular jack. Now, place an altitude encoder nylon spacer washer on the end of each screw (**Figure 15**).
  17. Thread the encoder wood screws into the starter holes in the right side panel with a Phillips screwdriver (**Figure 15**). The shaft on the altitude encoder assembly should protrude through the 5/8" through-hole in the right panel. It will take a bit of dexterity to keep the nylon spacer washers on the ends of the screws when installing, so don't get frustrated if it takes a couple tries. The screws should not be fully tightened; they should be tight, but not tight enough to prevent the altitude encoder from moving up and down within the slots in the encoder board.
- Note: The right panel does not have a white nylon bushing pressed into its 5/8" through hole like the left panel does. This is an intended design.*
18. There is a pilot hole above the altitude encoder assembly; this is where the plastic bumper (found in the IntelliScope kit) that protects the altitude encoder assembly will be installed. Take the remaining encoder wood screw from the IntelliScope kit, push it through the bumper, and use a Phillips screwdriver to thread it into the pilot hole until tight (**Figure 16**).
  19. Connect one end of the azimuth encoder cable (the shorter of the two flat cables in the IntelliScope kit) to



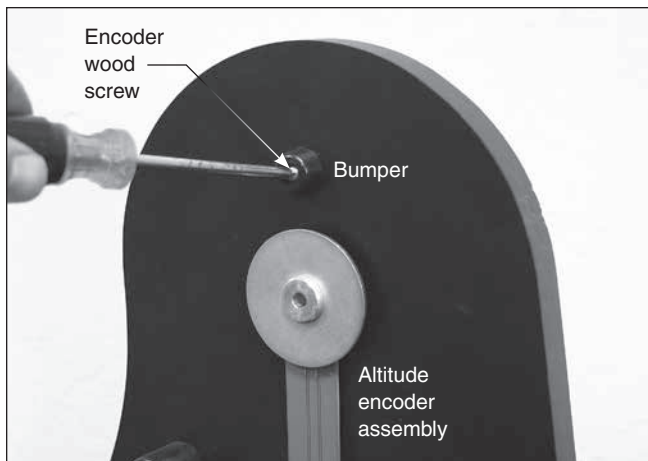
**Figure 15.** To install the altitude encoder assembly onto the interior surface of the right side panel, insert two encoder wood screws through the slotted holes in the board. Then, add an altitude encoder nylon spacer washer onto each screw. Now, insert the shaft of the altitude encoder through the hole in the right side panel, and thread the screws into the two pilot holes using a Phillips head screwdriver.

the encoder jack in the top baseplate of the Dobsonian base. Connect the other end to the encoder connector board installed on the base's left side panel. The azimuth encoder cable should plug into the jack on the *left* side of the encoder connector board (**Figure 14**).

20. Connect one end of the altitude encoder cable (the longer of the two flat cables in the IntelliScope kit) to the modular jack on the altitude encoder assembly. Connect the other end of the altitude encoder cable to the jack on the right side of the encoder connector board (**Figure 14**).
21. Use the cable clips provided with the IntelliScope kit to secure the altitude and azimuth cables neatly to the base. The clips have adhesive backing; simply peel the paper off the back of the clip and press the adhesive back to the base where you want the clip to be located.

*Note: Plan your placement of the clips carefully! If you intend to disassemble the side and front panels of the base for transport or storage, you should first disconnect the encoder cables from one or both of their respective jacks. And you will have to remove the cables from any cable clips on base surfaces where the cable is not plugged into a jack. So we recommend using as few cable clips as possible to make things easy during disassembly and re-assembly of the base.*

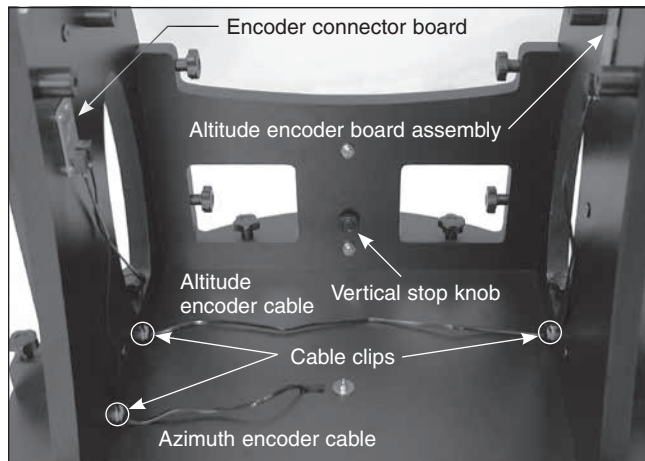
See **Figure 17** for recommended cable and cable clip placement. In that arrangement, only one clip is used to secure the (shorter) azimuth cable and two clips to secure the (longer) altitude cable. All three clips are affixed to the *side* panels. Before disassembling the side and front panels (we don't recommend disassembling the top baseplate from the ground baseplate), you would disconnect the azimuth cable from its jack in the top baseplate, and disconnect the altitude cable



**Figure 16.** Install the bumper into the pilot hole above the altitude encoder assembly using one of the encoder wood screws.

from its jack on the altitude encoder board and from the clip at the bottom of the right side panel. Both cables could be left connected to the encoder connector board on the left side panel.

22. Insert one end of the controller coil cable into the larger of the two jacks on the top of the IntelliScope Object Locator. Insert the other end into the “IntelliScope Computerized Controller Port” in the left panel of the Dobsonian base.
23. Two hook-and-loop strips (one strip of “hooks” and one strip of “loops”) have been provided to hang the IntelliScope Object Locator in a convenient location on the base when not in use. Place the “hooks” strip on the back of the controller, and the “loops” strip on the base in a convenient spot. Make certain the location of the strip on the base will not cause the Object Locator to interfere with the motions of the telescope. We recommend the placement shown in **Figure 1**. You may want to consider using the optional holster instead of the supplied hook-and-loop strips. The holster is a metal holder custom designed to fit the IntelliScope Object Locator. When installed at the top of the Dobsonian base, it provides a firm mounting for the Object Locator at a convenient position for easy access. The Object Locator can be removed or kept in the holster during use.
24. Slide the battery cover off the back of the Object Locator and insert the 9-volt alkaline battery. Make sure the positive and negative terminals of the battery are oriented as shown in the bottom of the battery compartment. Replace the battery cover.
25. Attach the handle (M in **Figure 7**) to the front brace (B) with the two handle screws. Place one handle washer on each screw, then press the handle against the front brace (the end of the handle with the Orion logo should be facing upwards). Thread the screws from the interior surface of the front brace into the handle until tight using the supplied crescent wrench.



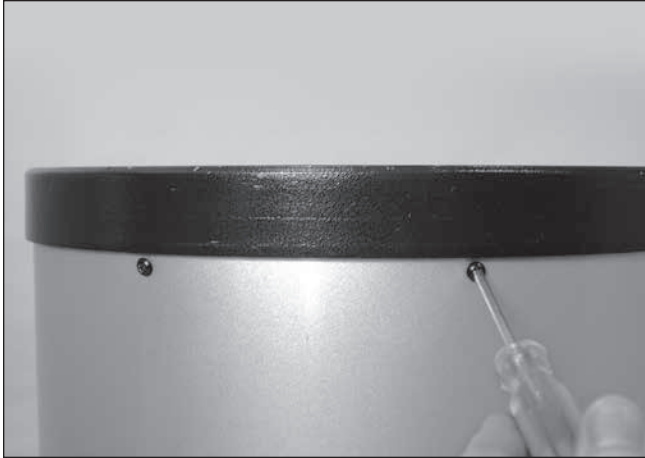
**Figure 17.** Recommended cable routing and cable clip placement. If you don’t intend to disassemble the base routinely for transport, you could use additional cable clips.

26. Thread the vertical stop knob into the threaded insert on the inside of the front brace (B) until just tight (**Figure 17**). The position of the vertical stop is adjusted by adding or removing one or more of the supplied thick and/or thin washers. Adjusting the vertical stop is required when using the IntelliScope Object Locator, since the optical tube must point precisely vertical during the initial alignment procedure. The manual included with the IntelliScope Object Locator kit details the procedure for adjusting the vertical stop. Once the vertical stop is properly adjusted, it should not need to be adjusted again for subsequent observing sessions.
27. The aluminum eyepiece rack holds three 1.25" eyepieces and one 2" eyepiece in a convenient place on the base, within easy reach while you’re observing. Above the oval cutout in the left side panel you will notice two pilot holes located approximately 6" apart. Thread the eyepiece rack screws into the holes with a Phillips screwdriver until the screw heads are about 1/8" from being flush with the side panel. Place the large portion of the eyepiece rack’s “keyhole” mounting slots over the two screw heads, then slide the rack downward. If you want to be able to remove the rack for transport or storage of the telescope, be sure the screws are loose enough so you can lift the rack and remove it from the base through the large opening of the “keyhole.” If you wish to permanently attach the rack to the base, tighten the two screws until the rack is secured in place.

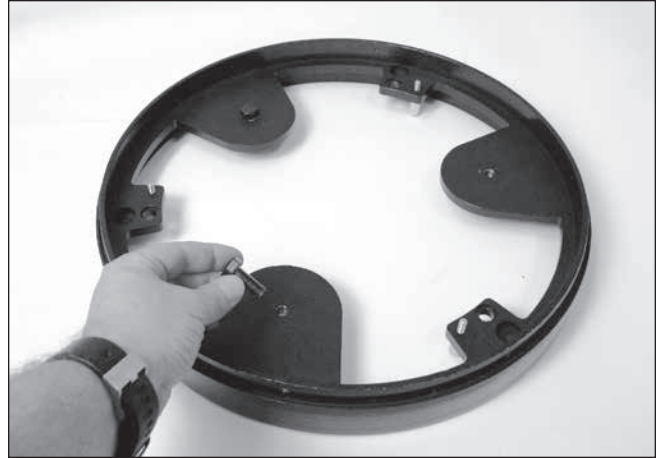
### Assembly of the Optical Tube

The primary mirror is shipped in its cell separately from the optical tube, to prevent possible damage to both the mirror and the optical tube. Once the primary mirror is installed in the telescope, there will be no need to remove the mirror, except if cleaning is necessary (see “Cleaning Mirrors”).

First, the mirror will be installed into the tube, then, the upper and lower sections of the tube will be assembled together with the truss poles.



**Figure 18.** To remove the rear end ring, unthread the eight screws that connect it to the tube.



**Figure 19.** Thread the three counterweight mounting bolts into the holes in the rear end ring and tighten them firmly with a wrench.



**Figure 20.** (a) Place the three springs on the exposed threaded shafts of the mirror cell. (b) Lower the rear end ring onto the mirror cell so that the threaded shafts of the mirror cell pass through the end ring, and the end ring rests on the springs. (c) Thread the collimation knobs, with nylon washers attached, through the rear end ring and onto the threaded shafts. Make sure the knobs have at least three full turns of engagement on the shafts.

1. To install the mirror into the optical tube, the rear end ring attached to the lower section of the optical tube must first be removed. This is done by unthreading and removing the eight Phillips-head screws that connect the end ring to the tube (**Figure 18**), and then pulling the end ring off of the tube.

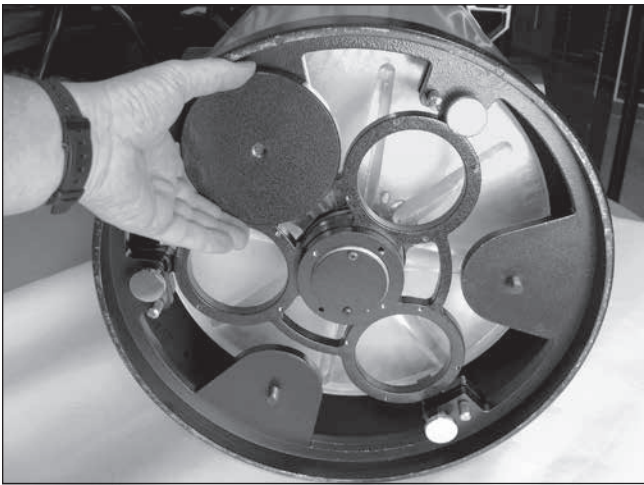
*Warning: Once the rear end ring is removed from the tube, the raw edge of the tube itself will be exposed. Be careful not to cut or otherwise hurt yourself on the tube's edge. Also be careful not to pinch your fingers when attaching the assembled mirror cell onto the tube.*

2. Thread the three counterweight mounting bolts into their respective holes in the rear end ring, as shown in **Figure 19**. The head of the bolts should be nearest to the primary mirror; the threaded end of the bolts should protrude outward, on the same side of the support structure as the collimation knobs. Use an adjustable wrench or a 16mm crescent wrench to firmly tighten the bolts.

3. Next, assemble the rear end ring to the mirror support cell. Find a clean, flat surface and place a clean cloth or towel on it. Turn the mirror cell over so that the mirror is facing downward; set it down on the cloth. Place the three springs onto the three exposed threaded shafts (**Figure 20a**). Lower the end ring onto the mirror cell so the threaded shafts pass through it, and the end ring rests on the springs (**Figure 20b**). Add a nylon washer to each collimation knob and thread the collimation knobs through the end ring and onto the threaded shafts (**Figure 20c**). Make sure the knobs have at least three full turns of engagement on the shafts. The mirror and end ring assembly is now ready to be installed onto the lower tube section.
4. Assembling the end ring (and mirror cell) back onto the tube can be a bit tricky. This is because the large diameter and thin metal of the tube will cause the tube to become somewhat out of round once the end ring is



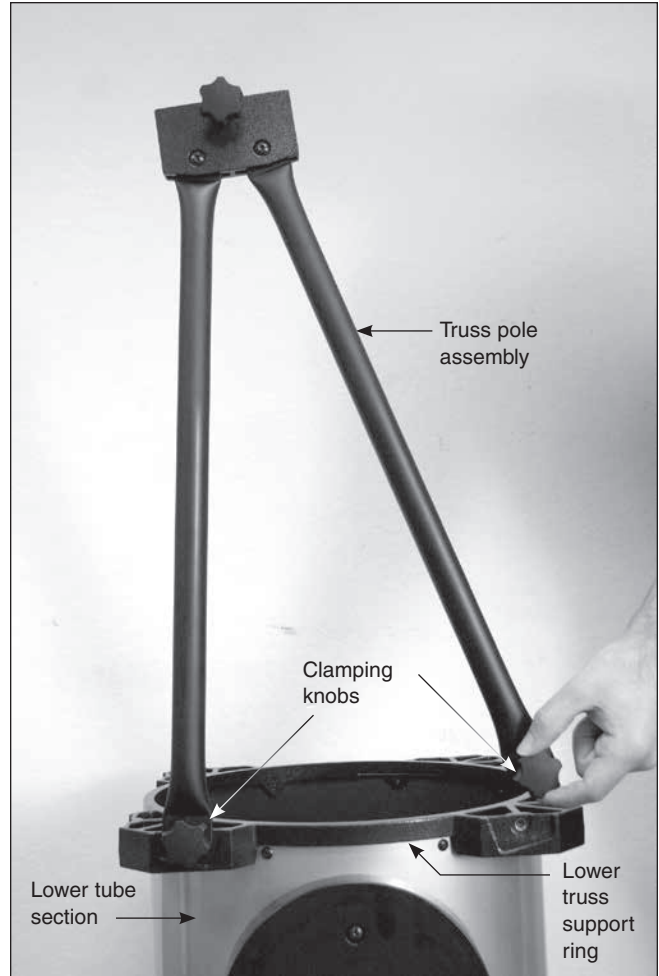
**Figure 21.** Locate the area of tube that is bulging out and preventing it from seating in the end ring. Press on the bulge to force the tube into the end ring.



**Figure 22.** Thread the counterweights onto the counterweight mounting bolts until each counterweight is tight against the metal plate. Install two counterweights on each mounting bolt.

removed. To assemble the rear end ring (with mirror and mirror cell now connected) to the tube, stand the lower section of the tube up vertically so the raw edge of the tube is up. Line up the threaded holes in the edge of the end ring with the holes in the end of the tube. Then, lower the entire assembly onto the tube. (Be careful to avoid finger pinching during this step!) There may be a bulge in the perimeter of the tube that prevents the end ring from fully seating onto the tube (**Figure 21**). Press against this bulge, and the entire mirror cell assembly should seat onto the tube. Now, replace the eight Phillips screws that connect the rear end ring to the tube.

5. The six counterweights can now be installed on the rear of the optical tube. Thread one counterweight onto each mounting bolt as far as it will go and tighten them lightly against the metal plate (**Figure 22**). Then thread on a



**Figure 23.** The clamping knobs on the ends of the truss pole assemblies thread into the holes in the lower truss support ring on the lower tube section.

second counterweight over top of the first one on each bolt. All six counterweights are needed to provide proper balance for the optical tube.

6. Now, the upper and lower sections of the tube will be connected with the four truss pole assemblies. This is a procedure that will be done whenever the telescope has been disassembled for transport or storage. It is very easy to do, and should only take a couple of minutes. Start by connecting the eight captive clamping knobs on the ends of the pole assemblies to the lower truss support ring on the lower optical tube section (**Figure 23**). This is done by simply threading the knobs into the holes in the ring. Do not completely tighten these knobs just yet.



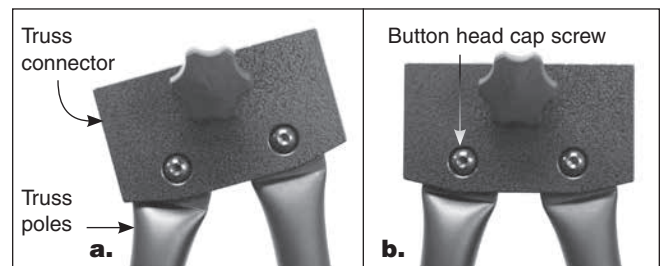
**Figure 24.** Rather than assembling the entire optical tube and then hoisting it onto the base, some may find it more convenient to mount the lower tube section on the base first, then install the truss tubes and upper tube section.

*Note: If desired, you can mount the lower tube section on the base before connecting the truss pole assemblies and upper tube section (Figure 24). You may find it easier to lift the lower tube section and guide it onto its resting place on the base's bearing cylinders than hoisting and mounting the fully assembled optical tube.*

7. Connect the upper tube section to the four truss connectors at the top of the poles. Orient the upper tube section as shown in **Figure 25**. Hold the upper tube section with one hand while threading the knobs in the truss connectors into the holes in the upper truss support ring. If necessary, you can slightly adjust the position of the truss connector with respect to the pole ends in order to have the knobs and holes line up (**Figure 26**). When tightened, the knob will clamp the truss connector against the registration flats on the upper truss support ring (**Figure 27**). Repeat this for the other three truss connectors. Firmly tighten the knobs.
8. Firmly tighten the eight clamping knobs on the lower truss support ring.
9. If, after assembling, the truss poles are loose within the truss connectors, use the supplied 4mm hex key to tighten the button head cap screws which connect the poles

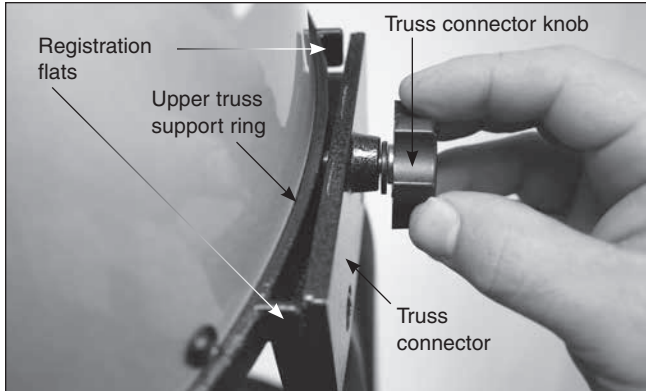


**Figure 25.** When the optical tube is assembled, the upper tube section should be oriented relative to the lower tube section as shown. Note the orientation of the focuser on the upper tube section relative to the side bearing on the lower tube section.



**Figure 26.** The position of the truss connectors relative to the pole ends can be adjusted to register the truss connectors with the upper truss support ring.





**Figure 27.** When the knob in the truss connector is tightened, it will clamp the truss connector against the registration flats on the upper truss support ring.



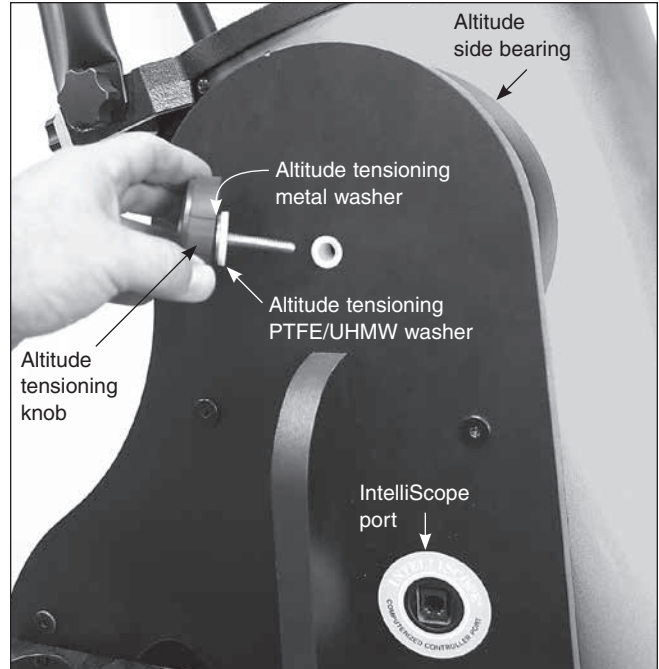
**Figure 28.** Lift the optical tube by grasping two truss poles and carefully lower it so that the large altitude bearing hubs rest on the altitude bearing cylinders on the side panels.

to the truss connectors (see **Figure 26**). This should rarely need to be done.

The telescope is now assembled and ready to be placed into the Dobsonian base.

### Mounting the Optical Tube on the Dobsonian Base

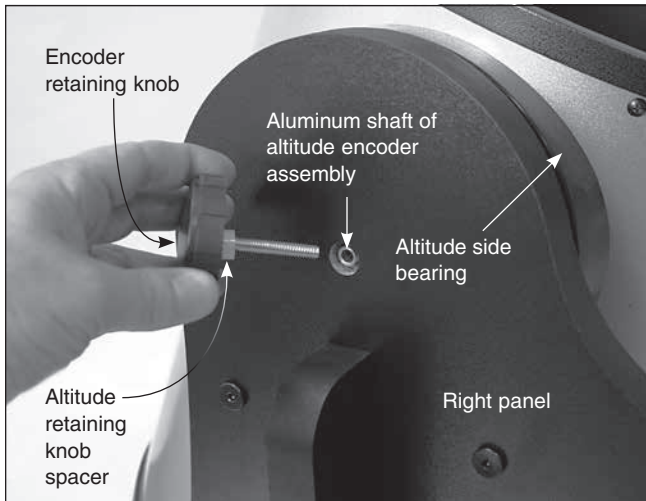
1. Grasp two opposing truss poles as shown in **Figure 28** and lift the optical tube, then gently place it into the Dobsonian base so the altitude bearings on either side of



**Figure 29.** Insert the shaft of the altitude tensing knob, with metal and PTFE/UHMW washers attached, into the side of the base with the IntelliScope port, and thread it into the tube's altitude side bearing.

the tube rest on the base's bearing cylinders. Be careful when doing this, as the optical tube is somewhat heavy and unwieldy. Orient the optical tube on the base as seen in **Figure 1**. Make certain the optical tube does not get hung up on the vertical stop or the CorrecTension pads (i.e. the three square white pads on the inside surface of the left side panel) as you put it in place. Also, be very careful not to hit the altitude encoder with the side bearing on the tube when doing this or damage to the encoder could result. The bumper is positioned to help prevent such contact. Once on the bearing cylinders, the tube should pivot freely up and down with gentle hand pressure. Note that the tube will not yet be properly balanced, since the eyepiece and finder scope are not in place, and the altitude tensing knob has not been installed.

2. Select one of the altitude tensing/retaining knobs (they are the same) and slide the tensing knob metal washer onto the shaft, followed by the tensing knob white PTFE/UHMW washer (you will need to thread the PTFE/UHMW washer onto the shaft, this keeps both washers captive on the knob's shaft). These parts are found in the box with the Dobsonian base. Push the shaft of the knob through the hole in the side panel that has the IntelliScope port (**Figure 29**). Thread the knob into the optical tube's altitude bearing until the knob pulls the altitude bearing against the CorrecTension pads on the interior surface of the left panel.



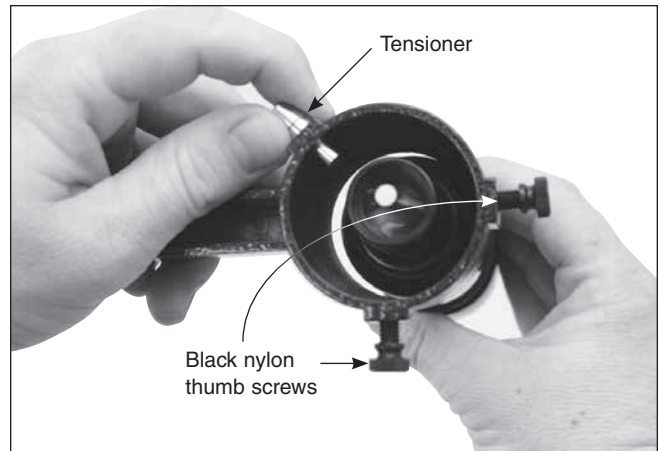
**Figure 30.** The shaft of the other knob (the retaining knob) goes through the hollow aluminum shaft of the altitude encoder and threads into the other altitude side bearing on the tube. Make sure to put the white nylon spacer on the shaft before threading it in.

3. On the other (retaining) knob, slide the altitude retaining knob spacer onto the threaded shaft. Then push the shaft through the altitude encoder's aluminum shaft (now protruding from the right side panel) and into the optical tube's other altitude bearing (**Figure 30**). You can move the altitude encoder up and down a bit with the knob in order to have the knob's shaft line up with the threaded hole in the tube's altitude bearing. Make sure this knob is always fully tightened, or else the IntelliScope's altitude encoder will not work properly.

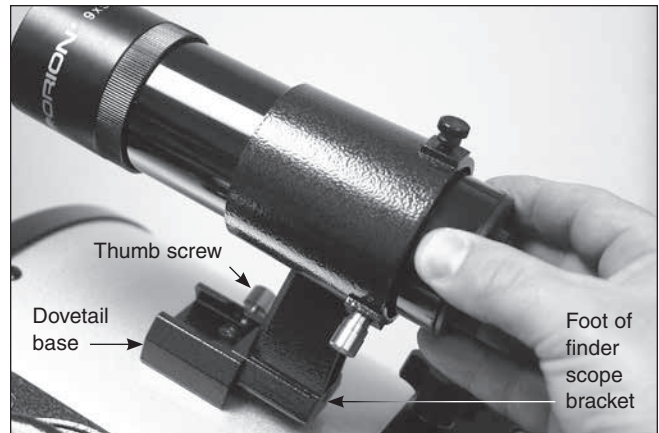
### Installing the Finder Scope and Eyepieces

These accessories can be found in the optical tube assembly box.

1. To install the finder scope into its bracket, first remove the O-ring from the bracket and place it over the body of the finder scope until it seats into the groove in the middle of the finder. Unthread the black nylon alignment screws on the bracket until the screw ends are flush with the inside

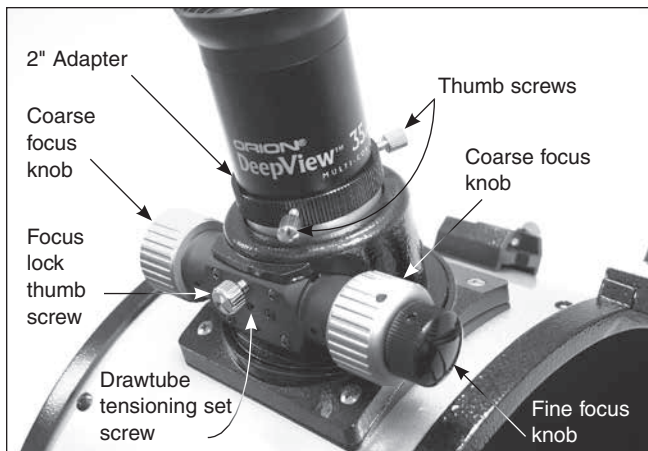


**Figure 31.** Pull back on the tensioner and slide the finder scope into its bracket until the O-ring is seated in the recess in the front of the bracket.

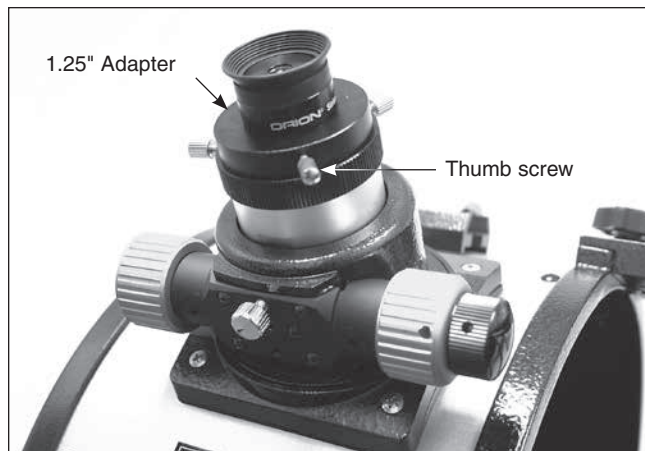


**Figure 32.** The foot of the finder scope bracket goes into the dovetail base and is secured with the thumb screw.

diameter of the bracket. Slide the eyepiece end (narrow end) of the finder scope into the end of the bracket's cylinder opposite the alignment screws while pulling the chrome, spring-loaded tensioner on the bracket with your



**Figure 33.** The 2" DeepView eyepiece installed in the focuser's 2" adapter.



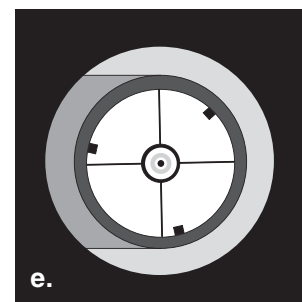
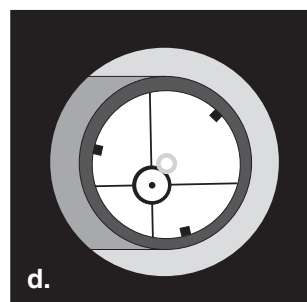
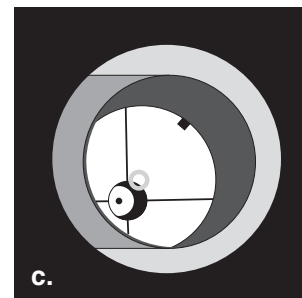
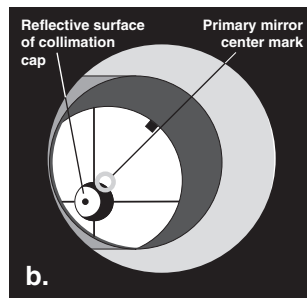
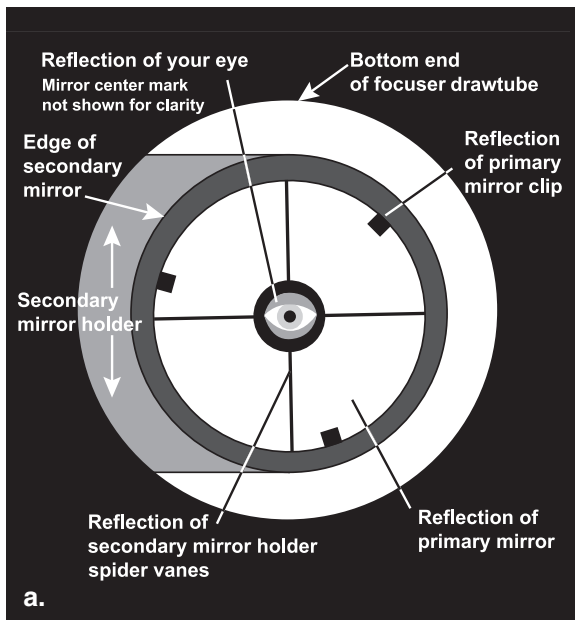
**Figure 34.** The 1.25" Sirius Plössl eyepiece installed in the focuser's removable 1.25" adapter.

fingers (**Figure 31**). Push the finder scope through the bracket until the O-ring seats just inside the front opening of the bracket. Release the tensioner and tighten the two black nylon screws a couple of turns each to secure the finder scope in place. The tips of the tensioner and nylon screws should seat into the wide groove on the finder scope's body.

2. Insert the foot of the finder scope bracket into the dovetail base located adjacent to the telescope's focuser (**Figure 32**). Lock the bracket into place by tightening the thumb screw on the dovetail base.
3. The final step in the assembly process is to insert an eyepiece into the telescope's focuser. First, take the cover cap off the focuser drawtube. To use the 2" DeepView eyepiece, loosen the two thumb screws on the 2" adapter (on the end of the focuser drawtube) and remove the 1.25" adapter. Then place the 2" eyepiece directly into the 2" adapter and secure it with the two thumb screws loosened previously (**Figure 33**). The other eyepiece and 1.25" adapter can be placed in the eyepiece rack until they are needed.

4. To install the 10mm Sirius Plössl eyepiece (1.25") instead of the 2" DeepView eyepiece, keep the 1.25" adapter in the focuser, and make sure the two thumb screws on the 2" adapter are tightened. Now, loosen the thumb screw on the 1.25" adapter; do not loosen the two thumb screws on the 2" adapter. Insert the 1.25" eyepiece into the 1.25" eyepiece adapter, and secure it by retightening the thumb screw on the 1.25" eyepiece adapter (**Figure 34**). The 2" eyepiece can be placed in the eyepiece rack until it is needed.

The basic assembly of your SkyQuest XX14i IntelliScope Dobsonian is now complete. It should appear as shown in **Figure 1**. The dust covers should always remain in place on the top of the upper and lower tube sections when the telescope is not in use. It is also a good idea to store eyepieces in an eyepiece case and to replace the cover caps on the focuser and finder scope when the telescope is idle.



**Figure 35.** Collimating the optics. **(a)** When the mirrors are properly aligned, the view down the focuser drawtube should look like this. **(b)** With the collimation cap in place, if the optics are out of alignment, the view might look something like this. **(c)** Here, the secondary mirror is centered under the focuser, but it needs to be adjusted (tilted) so that the entire primary mirror is visible. **(d)** The secondary mirror is correctly aligned, but the primary mirror still needs adjustment. When the primary mirror is correctly aligned, the center “dot” of the collimation cap will be centered in the ring on the primary mirror, as in **(e)**.

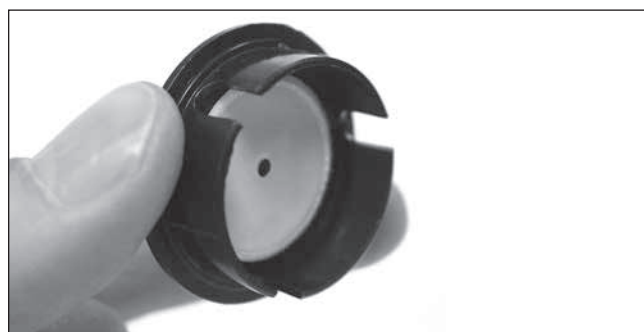
### 3. Aligning (Collimating) the Optical System

Collimating is the process of adjusting the mirrors so they are aligned with one another. Your telescope’s optics were aligned at the factory, and should not need much adjustment unless the telescope was handled roughly in transit. Accurate mirror alignment is important to ensure the peak performance of your telescope, so it should be checked regularly. Collimating is a relatively easy process and can be done in daylight or darkness.

To check collimation, remove the eyepiece and look down the focuser drawtube. You should see the secondary mirror centered in the drawtube, as well as the reflection of the primary mirror centered in the secondary mirror, and the reflection of the secondary mirror (and your eye) centered in the reflection of the primary mirror, as in **Figure 35a**. If anything is off-center, proceed with the following collimating procedure.

#### The Collimation Cap

Your XX14i comes with a “quick collimation cap” (**Figure 36**). This is a simple cap that fits on the focuser drawtube like a dust cap, but has a tiny hole in the center and a reflective inner surface. The collimation cap helps center your eye over the focuser drawtube so that aligning the optical components is easier to achieve. The reflective surface provides a distinct visual reference that is helpful in centering the mirror reflections. **Figures 35b through 35e** assume that you have the collimation cap in place.



**Figure 36.** The included “quick collimation cap” has a hole in the center and a reflective inner surface.

#### The Primary Mirror Center Mark

You’ll notice that the primary mirror of the XX14i has a small adhesive ring marking its center. This “center mark” allows you to achieve a very precise collimation; you don’t have to guess where the exact center of the mirror is.

*NOTE: The center ring sticker need not ever be removed from the primary mirror. Because it lies directly in the shadow of the secondary mirror, its presence in no way adversely affects the optical performance of the telescope or the image quality. That might seem counterintuitive, but it’s true!*

#### Preparing the Telescope for Collimating

Once you get the hang of collimating, you will be able to do it quickly even in the dark. For now, it is best to collimate in daylight, preferably in a brightly lit room and aimed at a light-colored wall. It is recommended that the telescope tube be oriented horizontally. This will prevent any parts from the secondary mirror from falling down onto the primary mirror



**Figure 37.** This image shows the XX14i properly set up for collimation. Note the white paper placed across from the focuser and the horizontal orientation of the optical tube. Ideally, the telescope should be pointing at a light-colored wall.

and causing damage if something comes loose while you are making adjustments. Place a sheet of white paper inside the optical tube directly opposite the focuser. The paper will provide a bright “background” when viewing into the focuser. When properly set up for collimation, your telescope should resemble **Figure 37**.

### Aligning the Secondary Mirror

To adjust the secondary mirror collimation, you will need a Phillips screwdriver and a 2mm hex key, or Allen wrench.

You will need to check, and adjust if necessary, four aspects of the secondary mirror’s alignment:

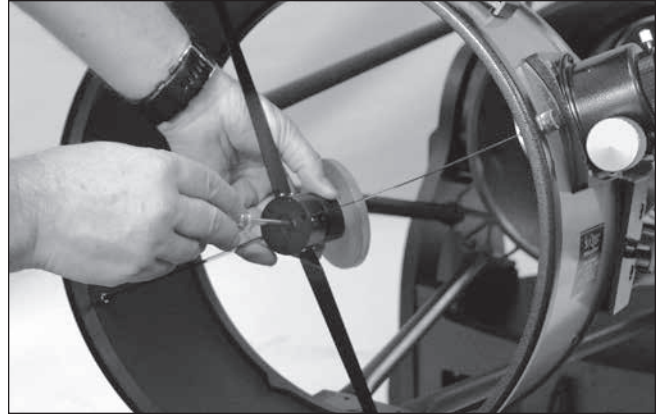
1. The secondary mirror’s axial position
2. The secondary mirror’s radial position
3. The secondary mirror’s rotational position
4. The secondary mirror’s tilt

The first three will probably only need to be checked and (possibly) adjusted once. Thereafter, it is usually only the secondary mirror’s tilt that will need to be adjusted occasionally.

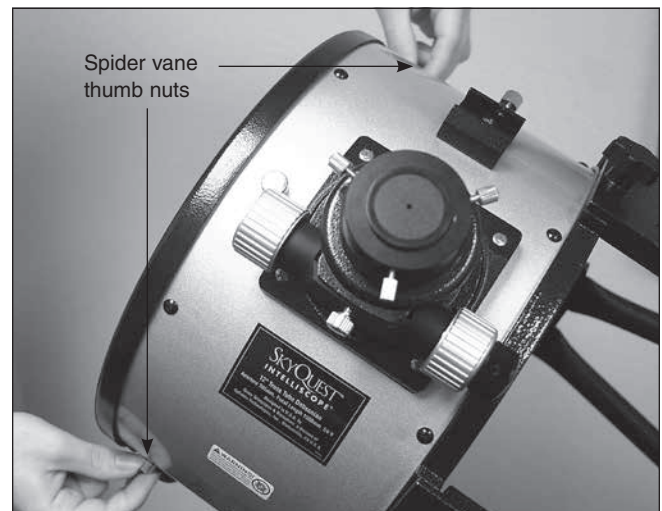
### Adjusting the Secondary Mirror’s Axial Position

With the collimating cap in place, look through the hole in the cap at the secondary (diagonal) mirror. Ignore the reflections for the time being. The secondary mirror itself should be centered in the focuser drawtube. If it is off-center along the axis of the telescope, i.e., positioned too far toward the front opening or toward the rear of the telescope, as it is in **Figure 35b**, you will have to adjust the mirror’s axial position.

To do so, use the 2mm hex key to loosen the three small alignment set screws in the center hub of the 4-vane spider several turns. Now, grasp the mirror holder (the cylinder that is attached to the back of the secondary mirror itself) with one hand while turning the center screw with a Phillips head screwdriver with your other hand (**Figure 38**). Turning the screw clockwise will move the secondary mirror toward the front opening of the optical tube, while turning the screw counter-clockwise will move the secondary mirror toward the



**Figure 38.** To center the secondary mirror axially under the focuser, hold the mirror holder in place with one hand while adjusting the center screw with a Phillips screwdriver.



**Figure 39.** To center the secondary mirror radially in the focuser drawtube, make adjustments to the two knurled spider vane thumb nuts that are perpendicular to the focuser.

primary mirror. When the secondary mirror is centered axially in the focuser drawtube, rotate the secondary mirror holder until the reflection of the primary mirror is as centered in the secondary mirror as possible. It may not be perfectly centered, but that is fine for now. Then, tighten the three small alignment set screws equally to secure the secondary mirror in that position.

### Adjusting the Secondary Mirror’s Radial Position

Like the axial position, the secondary mirror’s radial position was set at the factory and will probably not need any adjusting, or if it does, you’ll typically need to do it only once.

By “radial position” we mean the position of the secondary mirror along the axis perpendicular to the focuser drawtube, as shown in **Figure 39**. This position is changed by adjusting the two spider vane thumb nuts indicated in the figure. Loosen one thumb nut, then tighten the opposite one until the secondary mirror is centered radially in the drawtube. Do not loosen the thumb nuts too much, to avoid having them

completely unthread from the ends of the spider vanes. Also, when making this adjustment, be careful not to stress the spider vanes or they could bend.

### Adjusting the Secondary Mirror's Rotational Position

The secondary mirror should face the focuser squarely. If the mirror appears to be rotated away from the focuser, the mirror's rotational position will need to be adjusted. Again, this adjustment will rarely, if ever, need to be done.

Grip the sides of the secondary mirror holder with your fingers. Then, using a Phillips screwdriver, loosen the center screw in the secondary mirror holder about a quarter of a turn only (counterclockwise). That should be enough to free up the secondary mirror to rotate slightly in either direction. Look into the collimation cap and rotate the mirror slightly in each direction to get an idea of how it affects the view of the secondary mirror. Now rotate the mirror as needed so that it precisely faces the focuser. Hold the mirror holder stationary in that position while turning the center screw clockwise until it is just tight (do not over-tighten). Sometimes the mirror may rotate slightly when tightening the screw, so keep at it until the mirror faces the focuser squarely and is secured in place.

### Adjusting the Secondary Mirror's Tilt

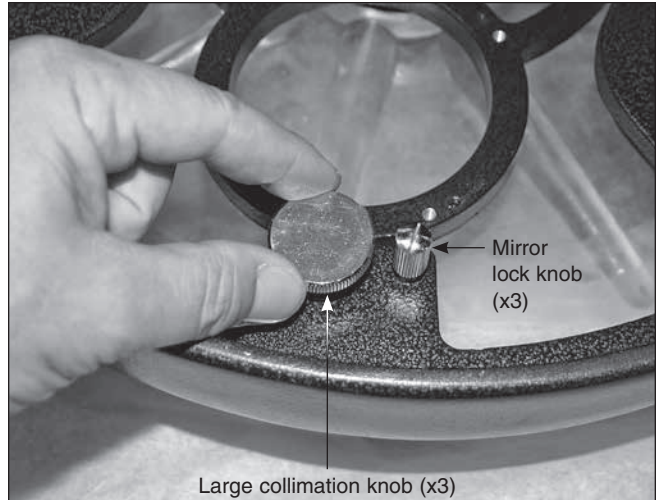
Finally, the tilt of the secondary mirror may occasionally require adjustment. If the entire primary mirror reflection is not visible in the secondary mirror when using the collimation cap, as in **Figure 35c**, you will need to adjust the tilt of the secondary mirror. Using a 2mm hex key, first loosen one of the three alignment set screws by, say, one full turn, and then tighten the other two to take up the slack. Do not loosen the center screw during this process. The goal is to center the primary mirror reflection in the secondary mirror, as in **Figure 35d**. When it is centered, you're done adjusting the secondary mirror. Don't worry that the reflection of the secondary mirror (the dark circle with the four spider vanes adjoining it) is off-center, since that adjustment is made when aligning the primary mirror in the next step.

### Aligning the Primary Mirror

The final collimation adjustment is made to the primary mirror. It will need adjustment if, as in **Figure 35d**, the secondary mirror is centered under the focuser and the reflection of the primary mirror is centered in the secondary mirror, but the reflection of the secondary mirror (dark circle containing the light reflective surface and center black "dot" of the collimation cap) is off-center.

The tilt of the primary mirror is adjusted with three spring-loaded collimation knobs on the back end of the optical tube (bottom of the primary mirror cell); these are the wide knobs (**Figure 40**). The three smaller knobs lock the mirror's position in place; these small knobs must be loosened before any collimation adjustments can be made to the primary mirror.

To start, turn the small knobs that lock the primary mirror in place counterclockwise a few turns each.



**Figure 40.** The tilt of the primary mirror is adjusted by turning one or more of the three large collimation knobs.

Now, turn one of the wide collimation knobs a half turn or so in either direction and see if the secondary mirror reflection moves closer to the center of the primary. That is, does the "dot" of the collimation cap appear to move closer to the ring on the center of the primary mirror? If it does, great, keep going until you get it as close as you can. If it doesn't, try turning the collimation knob in the opposite direction. If turning the one collimation knob does not seem to bring the dot closer to the ring, try using one of the other collimation knobs. It will take some trial-and-error using all three collimation knobs to properly align the primary mirror. Over time you will get the feel for which collimation knobs to turn to move the image in a given direction.

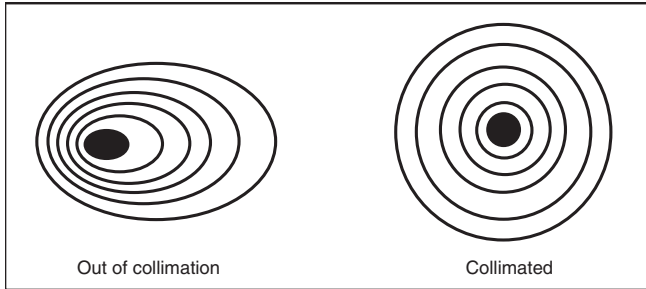
When you have the dot centered as much as possible in the ring, your primary mirror is collimated. Now lightly tighten the three thin locking knobs to secure the primary mirror in place.

The view through the collimation cap should now resemble **Figure 35e**. A simple star test will indicate how well the telescope optics are collimated.

### Star-Testing the Telescope

When it is dark, point the telescope at a bright star and accurately center it in the eyepiece's field of view. Slowly de-focus the image with the focusing knob. If the telescope is correctly collimated, the expanding disk should be a perfect circle (**Figure 41**). If the image is unsymmetrical, the scope is out of collimation. The dark shadow cast by the secondary mirror should appear in the very center of the out-of-focus circle, like the hole in a donut. If the "hole" appears off-center, the telescope is out of collimation.

If you try the star test and the bright star you have selected is not accurately centered in the eyepiece, the optics will always appear out of collimation, even though they may be perfectly aligned. It is critical to keep the star centered, so over time you will need to make slight corrections to the telescope's position in order to account for the sky's apparent motion. Polaris (the



**Figure 41.** A star test will determine if a telescope's optics are properly collimated. An unfocused view of a bright star through the eyepiece should appear as illustrated on the right if the optics are perfectly collimated. If the circle is unsymmetrical, as in the illustration on the left, the telescope needs collimation.

north star) is a good star to use for star testing, because it will not move out of the field of view.

#### Note About the 2" Crayford Focuser

The 2" Crayford focuser of the XX14i can be collimated using three pairs of push-pull screws located at the base of the focuser. The focuser was collimated at the factory, however, and should not need to be adjusted. Focuser collimating is only required under very rare circumstances, but has been made available for this telescope should such a need arise.

## 4. Using Your Telescope

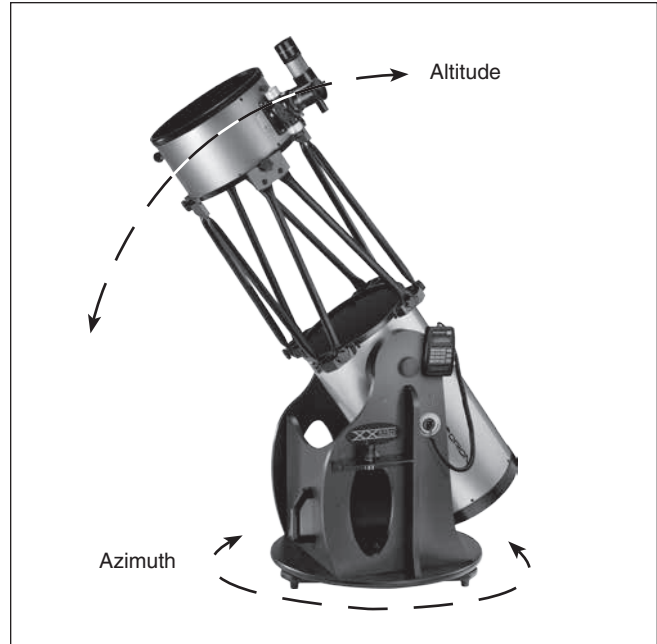
Before using your SkyQuest telescope for the first time at night, we recommend getting a feel for its basic functions during daylight hours. Find a spot outdoors where you have a clear view of some object or landmark that is at least 1/4-mile away. It is not critical that the base be exactly level, but it should be placed on somewhat flat ground or pavement to ensure smooth movement of the telescope.

Remember, never point the telescope at or near the Sun without using a proper solar filter over the front aperture.

#### Altitude and Azimuth Motion

The XX14i's Dobsonian base permits smooth motion of the telescope along two axes: altitude (up/down) and azimuth (left/right) (**Figure 42**). For altitude motion, the side bearings (made of heavy duty ABS plastic) on the telescope tube glide on pairs of bearing cylinders made from ultra-high molecular weight (UHMW) polyethylene. For azimuth motion, the Ebony Star laminate on the underside of the top baseplate rides on three Virgin PTFE/UHMW bearing pads attached to the ground baseplate. These choices of bearing materials provide optimum friction characteristics for moving the telescope when slewing or tracking.

To move the telescope, simply take hold of the navigation knob (black knob on upper tube section) and gently move the tube up or down and left or right as desired. Both motions can be made simultaneously and in a continuous manner for easy aiming.



**Figure 42.** Dobsonians have two axes of motion; altitude (up/down) and azimuth (left/right).

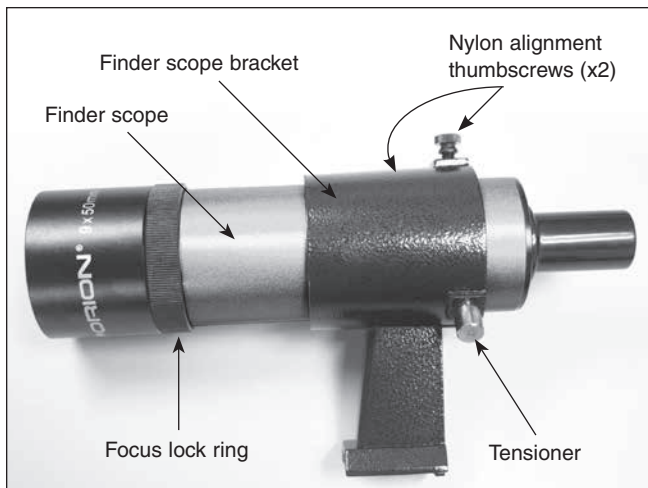
When the telescope is pointed high in altitude, rotating the tube in azimuth can cause the base to "tip" because of the reduced leverage. In this case it is helpful to place your other hand on the base or the optical tube to help "guide" the tube.

#### Setting the Altitude Tension

A nice feature of the SkyQuest IntelliScope Dobsonians is the redesigned CorrecTension system. Because of their relatively light weight, smaller Dobsonians (under 16") have always been plagued by insufficient friction on the altitude bearing surfaces. As a result, such telescopes move up and down much too freely. This causes problems when the observer tries to accurately center and track an object for viewing, especially at higher powers. Also, the telescope becomes very sensitive to balance. SkyQuest IntelliScope Dobsonians employ a simple yet effective remedy for the friction problem. CorrecTension Friction Optimization utilizes a simple "disc brake" to apply the correct level of tension to the altitude bearings. With this system, you can change eyepieces or add a barlow lens without having to tediously adjust the telescope's balance as you would with other Dobsonians.

The telescope should move smoothly with just gentle hand pressure. While azimuth friction is not adjustable, the altitude friction can be adjusted to the desired level by loosening or tightening the altitude tensioning knob. Note that the altitude tensioning knob is the knob on the same side of the base as the IntelliScope Controller Port. The knob on the opposite side of the base is merely an encoder retaining knob; it does not affect altitude tension and should always be fully tightened.

A good way to set the altitude tension is to point the telescope at about a 45° angle. Then, turn the altitude tensioning knob until the altitude motion feels roughly equal to the azimuth motion; this ensures optimal performance. The motion should



**Figure 43.** The 9x50 finder scope and dovetail bracket.

be ideal – not too stiff, not too loose. You will want to be able to “track” the motion of celestial objects while viewing them by making small movements of the telescope without experiencing jerking (too much tension) or overshooting of the desired position (too little tension).

### Focusing the Telescope

The XX14i comes standard with a 2" dual-speed Crayford focuser (**Figure 33**). The large 2" format focuser allows use of 2" or 1.25" eyepieces and the Crayford design prevents imaging shifting while focusing. The focuser has coarse focus knobs and a fine focus knob (11:1) for precise focusing.

With the 35mm Deep View eyepiece in the focuser and secured with the thumb screws, move the telescope so the front end is pointing in the general direction of an object at least 1/4-mile away. Now, with your fingers, slowly rotate one of the coarse focus knobs until the object comes into sharp focus. Go a little bit beyond sharp focus until the image just starts to blur again, then reverse the rotation of the knob, just to make sure you're close to the focus point.

Now, use the fine focus knob to achieve precise focus. Eleven turns of the fine focus knob is equivalent to one turn of the coarse focus knobs, so much finer adjustment is possible than with just the coarse focus knobs alone. You'll find this is a great convenience, especially when attempting to focus at high magnifications.

If you have trouble focusing, rotate the coarse focusing knob so the drawtube is inward as far as it will go. Now look through the eyepiece while slowly rotating the focusing knob in the opposite direction. You should soon see the point at which focus is reached.

The thumb screw on the bottom of the body of the focuser (**Figure 33**) will lock the focuser drawtube in place once the telescope is properly focused. Before focusing, remember to first loosen this thumb screw.

If you find the drawtube tension when focusing is either too tight (i.e., focus knob is difficult to turn) or too loose (i.e.,



**Figure 44.** The view through a straight finder scope (and a reflector telescope) is rotated 180°.

drawtube moves by itself under the weight of the eyepiece), you can adjust it by tightening or loosening the drawtube tensioning set screw on the focuser, which is located just below the focus lock thumb screw (**Figure 33**). Adjust this set screw with the included 2.5mm hex key. Do not loosen the set screw too much as there must be some tension to keep the drawtube secure within the focuser. The other set screw below the drawtube tensioning set screw does not affect drawtube tension and should not be adjusted.

### Viewing with Eyeglasses

If you wear eyeglasses, you may be able to keep them on while you observe, if your eyepieces have enough eye relief to allow you to see the whole field of view. You can try this by looking through the eyepiece first with your glasses on and then with them off, and see if the glasses restrict the view to only a portion of the full field. If they do, you can easily observe with your glasses off by just refocusing the telescope as needed. If you suffer from severe astigmatism, however, you may find images noticeably sharper with your glasses on.

### Aligning the Finder Scope

Your SkyQuest XX14i comes with a high-quality, large-aperture 9x50 achromatic crosshair finder scope as standard equipment (**Figure 43**). This greatly aids in finding alignment stars and objects to view in the night sky. The finder scope must be accurately aligned with the telescope for proper use. The finder scope uses a spring-loaded bracket which makes alignment very easy. As you turn either of the thumb screws, the spring in the bracket's tensioner moves in-and-out to keep the finder scope secure in its bracket.

To align the finder scope, first aim the main telescope in the general direction of an object at least 1/4-mile away — the top of a telephone pole, a chimney, etc. Position that object in the center of the telescope's eyepiece.

*Note: The image in the finder scope and the telescope will appear rotated 180°. This is normal for finder scopes and reflector telescopes (**Figure 44**).*



Now look through the finder scope. Ideally, the object should be within the field of view. If not, then coarse adjustments to the bracket's alignment thumb screws will be needed. Once the image is in the finder scope's field of view, you will now use the bracket's alignment thumb screws to center the object on the intersection of the crosshairs. By loosening or tightening the alignment thumb screws, you change the line of sight of the finder scope. Continue making adjustments to the alignment thumb screws until the image is centered in both the finder scope and the telescope's eyepiece.

Check the alignment by moving the telescope to another object and fixing the finder scope's crosshairs on the exact point you want to look at. Then look through the telescope's eyepiece to see if that point is centered in the field of view. If it is, the job is done. If not, make the necessary adjustments until the two images match up.

The finder scope alignment should be checked before every observing session. This can easily be done at night, before viewing through the telescope. Choose any bright star or planet, center the object in the telescope eyepiece, and then adjust the finder scope bracket's alignment thumb screws until the star or planet is also centered on the finder's crosshairs. You'll find the finder scope to be an invaluable tool for locating objects in the night sky.

### Focusing the Finder Scope

The finder scope with your XX14i has adjustable focus. If the images in the finder appear somewhat out of focus, you will need to refocus the finder scope for your vision. Loosen the focus lock ring located behind the objective lens cell on the body of the finder scope (**Figure 43**). Back the lock ring off by a few turns, for now. Focus the finder scope on a distant object by threading the objective lens cell in or out on the finder scope body. Precise focusing will be achieved by focusing the finder scope on a bright star. Once the image appears sharp, retighten the lock ring behind the objective lens cell. The finder scope's focus should not need to be adjusted again.

### Aiming/Pointing the Telescope

With the finder scope aligned, the telescope can be quickly and accurately pointed at anything you wish to observe. The finder scope has a much wider field of view than the telescope's eyepiece, and therefore it is much easier to find and center an object in the finder scope. Then, if the finder scope is accurately aligned, the object will also be centered in the telescope's field of view. Start by once again moving the telescope until it is pointed in the general direction of the object you want to see. Some observers find it convenient to sight along the tube to do this.

Now, look in the finder scope. If your general aim is accurate, the object should appear somewhere in the field of view. Make small adjustments to the telescope's position until the object is centered on the finder's crosshairs. Now, look in the telescope's eyepiece and enjoy the view!

### Magnification

Now that the object you want to view is centered in the 35mm eyepiece, you may want to increase the magnification to get a closer view. Loosen the thumb screws on the focuser drawtube and remove the eyepiece. Place it in the eyepiece rack, if you wish. Place the 1.25" eyepiece adapter into the focuser and secure it with the two thumb screws. Insert the 10mm eyepiece into the 1.25" eyepiece adapter, and tighten the thumb screw on the 1.25" adapter. If you were careful not to bump the telescope, the object should still be visible in the field of view. Notice that the object being viewed is now larger, but somewhat dimmer.

Magnification, or power, is determined by the focal length of the telescope and the focal length of the eyepiece. Therefore, by using eyepieces of different focal lengths, the resultant magnification can be varied.

Magnification is calculated as follows:

$$\frac{\text{Telescope Focal Length (mm)}}{\text{Eyepiece Focal Length (mm)}} = \text{Magnification}$$

The XX14i has a focal length of 1650mm. So, the magnification with the supplied 35mm eyepiece is:

$$\frac{1650\text{mm}}{35\text{mm}} = 47\text{x}$$

The magnification provided by the 10mm eyepiece is:

$$\frac{1650\text{mm}}{10\text{mm}} = 165\text{x}$$

The maximum attainable magnification for a telescope is directly related to how much light its optics can collect. A telescope with more light-collecting area, or aperture, can yield higher magnifications than a smaller aperture telescope. The maximum practical magnification for any telescope, regardless of optical design, is about 50x per inch of aperture. This translates to about 700x for the XX14i. Of course, such high magnification will only yield acceptable images if atmospheric conditions are favorable.

More typically, useful magnifications will be limited to 200x or less, regardless of aperture. This is because the Earth's atmosphere distorts light as it passes through. On nights of good "seeing," the atmosphere will be still and will yield the least amount of distortion. On nights of poor seeing, the atmosphere will be turbulent, which means different densities of air are rapidly mixing. This causes significant blurring of the incoming light, which prevents sharp views at high magnifications.

Keep in mind that as magnification is increased, the brightness of the object being viewed will decrease; this is an inherent principle of the physics of optics and cannot be avoided. If magnification is doubled, an image appears four times dimmer. If magnification is tripled, image brightness is reduced by a factor of nine!

The XX14i is designed to accept eyepieces with a barrel diameter of either 1.25" or 2". At low magnifications, 2" eyepieces can provide a wider field of view than standard 1.25"

eyepieces. A wider field can be desirable for viewing extended deep-sky objects that are too large to fit within a narrower field of view.

### Tube Balance

With the six 2.3-lb. counterweights installed on the back of the rear cell, the XX14i optical tube will achieve proper balance with its supplied accessories. For heavier front-end loads, such as if you use a solar filter on the front of the scope or a heavier eyepiece, the CorrecTension system of the XX14i can be adjusted to compensate for the added weight, to maintain good tube balance. Simply tighten the altitude tensioning knob on the left side of the base as needed to keep the front of the tube from spontaneously drifting downward.

### Disassembling the Telescope for Transport

Despite being a large-aperture instrument, the XX14i has been designed to be easy to transport. The optical tube uncouples from the base, the optical tube disassembles into manageable chunks, the base breaks down quickly into four main components, and each component can be carried separately.

Before disassembling the telescope, remove the finder scope (with bracket) and any eyepieces from the optical tube, and remove the IntelliScope Object Locator from the base. The eyepiece rack can also be removed from the base, if you wish. This will prevent these accessories from being damaged during transport. These items can be placed in optional accessory cases.

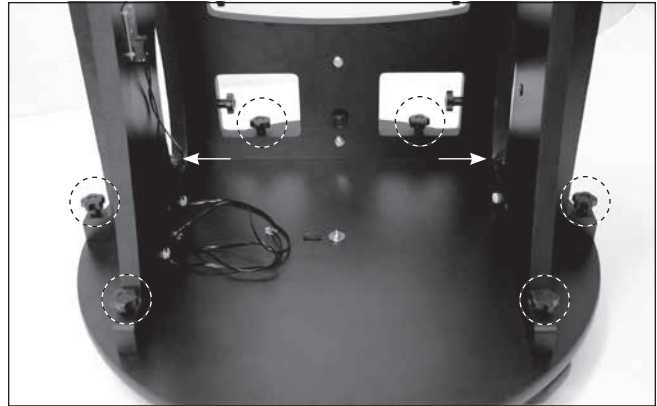
### Disassembly of the Optical Tube

To remove the optical tube from the base, simply unthread the altitude tensioning knob and altitude retaining knob from the tube's altitude side bearings until they are free of the tube and base. (Be careful to not lose the small spacer on the altitude retaining knob shaft; see **Figure 30**). Then, using both hands, carefully lift the tube off the base and set it on the ground. It is convenient to lift the tube by grasping opposing truss poles (**Figure 28**). The tube is somewhat heavy, so don't hesitate to have a friend help lift it, if necessary.

*Note: If you choose to thread the knobs back into the altitude bearings after removing the optical tube from the base, be careful not to put weight or stress on the knobs when transporting the telescope, or the knob shafts could bend.*

To disassemble the optical tube, unthread the knobs in the truss pole connectors from the upper truss support ring while holding the upper tube section. Once all four knobs are unthreaded, remove the upper tube section. Now, unthread the eight knobs on the pole ends from the lower truss support ring, and remove the truss pole assemblies from the lower tube section. Place the dust covers on the tops of the upper and lower tube sections. The telescope is now disassembled and ready to be transported.

*Note: In step 5 of Assembly of the Optical Tube, it was suggested that the lower tube section could be installed on the base before attaching the truss poles and upper tube section. Likewise, to avoid having to lift the entire optical tube assem-*



**Figure 45.** Before disassembling the base for transport, be sure to disconnect the encoder cables from the encoder board jacks and from any cable clips on surfaces other than the left side panel. To remove the side panel/front panel structure from the top baseplate, loosen the eight captive connecting bolts that attach the structure to the baseplate. You'll have to turn each hand knob at least seven full turns to completely disengage the bolts.

*ably off the base, you could disassemble the top tube section and then remove the truss poles while the lower tube section is still mounted on the base. Then, remove the tensioning and retaining knobs from the side bearings, grasp the tube by the upper end ring with both hands, and lift it off the altitude bearing cylinders and set it on the ground.*

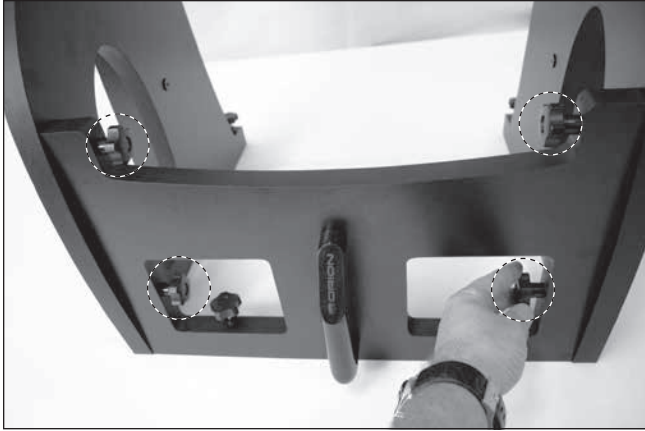
We recommend keeping the counterweights attached to the rear cell. But if you wish to remove them for transport – which will make the lower tube section nearly 14 lbs. lighter – just be sure to re-mount them before placing the optical tube on the base the next time you reassemble the telescope, or else the tube will be out of balance, i.e., front heavy, and could swing forward.

If possible, we recommend transporting the lower optical tube section in the upright position, with the mirror parallel to the ground. This isn't absolutely necessary, but doing so will minimize the stress on the mirror's edge from the retaining bolts and retaining washers, especially when going over bumps in the road.

### Disassembly of the Base

When fully assembled, the XX14i's base is somewhat bulky. But is was cleverly designed to permit quick disassembly into smaller components, allowing it to fit into a smaller space – in a standard size car trunk or back seat, for instance – for transport to a remote observing location. If you choose not to disassemble the base, you may be able to carry it with the convenient carry handle. But use caution – it's heavy!

1. Disconnect the azimuth encoder cable from the azimuth encoder jack in the top baseplate. Then disconnect the altitude encoder cable from the altitude encoder jack on the right side panel, and remove the cable from the cable clip on the right side panel (**Figure 45**). If desired, you could also completely disconnect both cables by also disconnecting them from the encoder connector board and from the two cable clips on the left side panel.



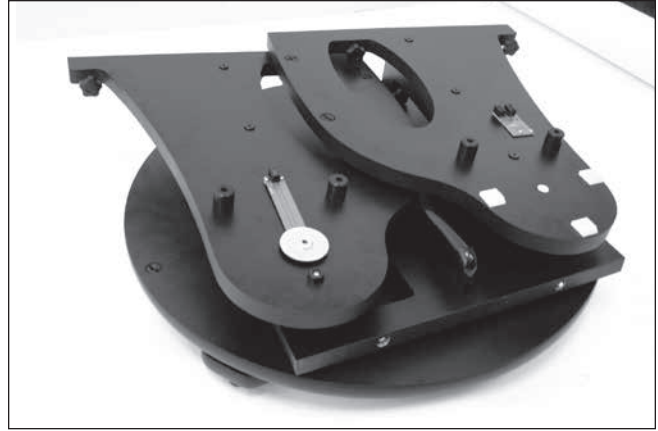
**Figure 46.** Loosen the four captive connecting bolts that attach the side panels to the front panel.

2. Loosen the eight captive connecting bolts that attach the side and front panels to the top baseplate (**Figure 45**). You will have to turn the hand knobs about seven full turns or so to unthread the bolts completely from their receptacles in the top baseplate. Remember, the bolts are captive so they will not come out when they are disengaged. When you have loosened each bolt seven full turns or so, lift the side panel/front panel structure off of the top baseplate and set it down next to the baseplate assembly. Do not disassemble the top baseplate from the bottom baseplate.
3. To remove the side panels from the front panel, loosen the four captive connecting bolts that attach the front panel to the side panels (**Figure 46**). You will have to turn the hand knobs about seven full turns or so to unthread the bolts completely from their receptacles in the side panels.

Now the base has been broken down into four component pieces: the baseplate assembly, the two side panels (with side braces attached), and the front panel. To prevent damage to the encoder connecting board and the altitude encoder assembly on the base side panels, we recommend that you not stack anything on those surfaces, and keep them facing up during transport (**Figure 47**).

When putting the XX14i into a vehicle, common sense prevails. It is important that the optical tube sections do not get knocked around; this can cause the optics to become misaligned, and could dent the tube. We recommend transporting (and storing) the tube assembly in the optional padded case set for proper protection. The case set includes a two padded cases for the tube sections, plus a pole case that holds the four truss pole assemblies, and a secondary mirror cover. All the cases have carry handles, and one of the padded cases has an accessory pocket for added convenience.

To reassemble the telescope, just reverse the disassembly procedure above.



**Figure 47.** When transporting the disassembled base, lay the side panels so the encoders face upward and don't stack anything on top of them, to prevent their getting damaged.

## 5. Astronomical Observing

The SkyQuest XX14i IntelliScope Truss Tube Dobsonian provides prodigious capability for observing the many wonders of the heavens, from the major planets to deep-space nebulas and galaxies. In this section we give you some astronomical observing tips and briefly summarize what you can expect to see.

### The IntelliScope Computerized Object Locator

One of the most exciting features of the XX14i is its compatibility with the IntelliScope Computerized Object Locator. When plugged into the IntelliScope port on the base, the Object Locator enables the user to point the telescope quickly and effortlessly to more than 14,000 astronomical objects with the push of a few buttons. After a simple two-star alignment procedure, you just select an object to view from the intuitive keypad, then read the guide arrows on the Object Locator's illuminated liquid crystal display and move the telescope in the corresponding direction. In seconds, the object will be waiting in the telescope's field of view, ready to observe. It's that simple!

The two guide arrows and associated "navigation numbers" tell you in what direction to move the telescope to pinpoint an object's location. As the telescope approaches the object's location, the numbers get progressively smaller. When the navigation numbers reach zero, the telescope will be pointed right at the object. You just look into the eyepiece and enjoy the view!

The IntelliScope Computerized Object Locator works by communicating electronically with the pair of high-resolution, 9,216-step digital encoders installed in the base. The encoders allow highly precise positioning of the telescope to coordinates programmed into the Object Locator's database for each astronomical object. Since the telescope is not dependent on motors for movement, you can point the telescope at your target much more quickly (and quietly!) than other computerized telescopes can – and without guzzling all those batteries in the process.

The Object Locator's database includes:

- 7,840 objects from the Revised New General Catalog (NGC)
- 5,386 objects from the Index Catalog (IC)
- 110 objects from the Messier Catalog (M)
- 837 selected stars (mostly double, multiple, and variable stars)
- 8 planets
- 99 user-programmable objects

With the user-friendly IntelliScope Object Locator, there are many ways to locate an astronomical object. If you know its catalog number (NGC or M number, for instance), you can enter it using the illuminated keypad buttons. Or you can press one of the object category buttons (Cluster, Nebula, Galaxy, etc.) to access a list of objects by type. For a tour of the best objects visible in a given month, you just press the Tour button.

Another great feature of the IntelliScope is the ability to identify an “unknown” object in the field of view – just press the ID button. You can even add up to 99 objects of your own choosing to the Object Locator's database. The backlit, two-line LCD on the Object Locator shows you the object's catalog number, its common name if it has one, the constellation in which it resides, its right ascension and declination coordinates, the object type, magnitude, angular size, as well as a brief description in scrolling text.

The IntelliScope Object Locator is a wonderful convenience for both the novice and experienced observer. You'll spend more time actually observing astronomical objects instead of hunting for them. For instructions on how to operate the Object Locator, refer to the instruction manual included in the box with the IntelliScope Object Locator kit.

### Selecting an Observing Site

Since most astronomical objects are faint, observing them from dark skies will give you the best views. While some objects, such as the planets and Moon, are bright enough to see clearly even from light-polluted city skies, for nebulae, galaxies, and most star clusters, the less ambient light there is to reduce contrast, the better.

When it isn't possible or convenient to get out of town to a pitch-black observing location, try to set up in a spot that is removed from street and building lights and that has a clear view of a large portion of the sky. Avoid pointing the telescope above buildings, if possible, since they radiate heat which degrades images. For observing faint deep sky objects, choose a moonless night or time of night. Using the optional light shroud will be a necessity (see below). Also, use of a light-pollution filter, like the Orion SkyGlow Broadband filter, can mitigate the effects of background sky brightness, enhancing the view of faint objects.

### Use of the Optional Light Shroud

When viewing from light-polluted skies, we highly recommend using the optional light shroud for the XX14i. The light shroud



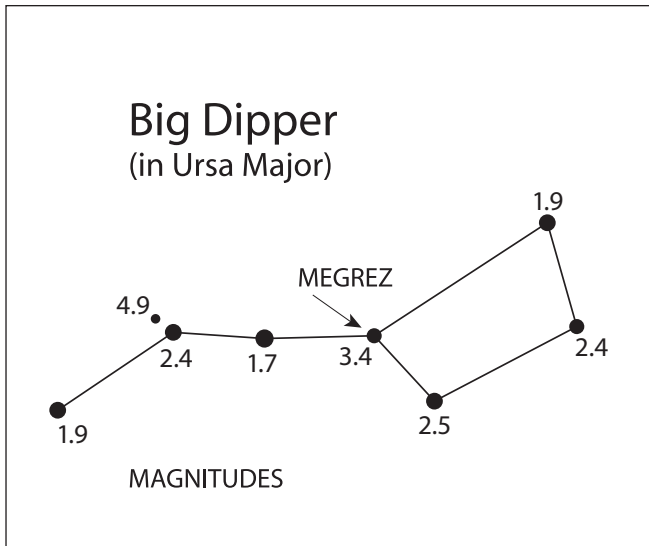
**Figure 48.** The optional light shroud for the XX14i prevents stray light from entering the telescope. It also helps prevent dew from forming on the optical surfaces.

is a black nylon cloth wrap that fits over the exterior of the truss poles (**Figure 48**). The shroud prevents stray light from entering the telescope through the open truss section of the tube and degrading image contrast. The shroud also helps prevent dew from forming on the optical surfaces of the telescope.

### Seeing and Transparency

Atmospheric conditions play a huge part in quality of viewing. Light from stars and other celestial objects must travel through miles of Earth's atmosphere to reach our eyes. The air in the atmosphere will refract and bend the light. Atmospheric turbulence will worsen the effects of refraction, which can cause the image you see in your telescope to be unstable. The steadiness of the atmosphere is called the “seeing” condition.

In conditions of good seeing, star twinkling is minimal and objects appear steady in the eyepiece. Seeing is best overhead, worst at the horizon. Also, seeing conditions generally get better later in the evening, as much of the heat absorbed by the Earth during the day has radiated off into space. In



**Figure 49.** Megrez connects the Big Dipper's handle to its "pan." It is a good guide to judging the transparency of the night sky. If you cannot see Megrez (a 3.4-magnitude star), then the transparency is poor.

conditions of bad seeing, stars will twinkle and objects will appear unsteady and blurry in the telescope.

"Transparency" is the clarity of the atmosphere, which can be adversely affected by the presence of moisture, smoke, and dust. All tend to scatter light, which reduces an object's brightness. Good transparency is desirable for astronomical observing, especially for viewing faint objects.

One good measure of transparency is by how many stars you can see with your unaided eyes. If you cannot see stars of magnitude 3.5 or dimmer, then transparency is poor. Magnitude is a measure of how bright a star is. The brighter a star, the lower its magnitude. A good star to remember for this is Megrez (magnitude 3.4), which is the star in the Big Dipper that connects the handle to the "pan" (**Figure 49**). If you cannot see Megrez, then you have fog, haze, clouds, smog, light pollution or other conditions that are hindering your viewing.

### Cooling the Telescope

All optical instruments need time to reach thermal equilibrium with the outdoor air, which is essential for peak performance. Images will be poor if the optics are not in equilibrium with the outdoor temperature.

When moved from a warm indoor location to cooler outside air (or vice-versa), a telescope needs time to equilibrate to the outdoor temperature. The bigger the instrument and the larger the temperature change, the more time will be needed. The open truss tube design of the XX14i promotes good air ventilation of the optics, but it will still require at least 30 minutes or so to equilibrate. If the temperature difference between indoors and outdoors is more than 40°, it will likely take longer. In the winter, storing the telescope outdoors in a shed or garage greatly reduces the amount of time needed for the optics to stabilize. Also, after setting up outdoors, it is a good

idea to keep the telescope covered until the Sun sets so the tube does not heat greatly above the temperature of the air.

The primary mirror supplied with this XX14i IntelliScope has a new, lower-mass design with a convex, ribbed back. This design promotes more rapid cooling and does not require a complicated multi-point support structure as the previous, flat-back mirror did. For even more rapid cooling of the mirror, its support cell has 12 predrilled and tapped holes for an optional three-fan cooling system (#7818).

### Let Your Eyes Dark-Adapt

Do not expect to go from a lighted house into the darkness of the outdoors at night and immediately see faint nebulas, galaxies, and star clusters – or even very many stars, for that matter. Your eyes take about 30 minutes to reach perhaps 80% of their full dark-adapted sensitivity. Many observers notice improvements after several hours of total darkness. As your eyes become dark-adapted, more stars will glimmer into view and you will be able to see fainter details in objects you view in your telescope. Exposing your eyes to very bright daylight for extended periods of time can adversely affect your night vision for days. So give yourself at least a little while to get used to the dark before you begin observing.

To see what you are doing in the darkness, use a red-filtered flashlight rather than a white light. Red light does not spoil your eyes' dark adaptation like white light does. A flashlight with a red LED light is ideal. Dim light is preferable to bright light.

Be aware, too, that nearby porch and streetlights and automobile headlights will spoil your night vision. Close your eyes when you hear an automobile approaching your observing site!

### Eyepiece Selection

By using eyepieces of different focal lengths, it is possible to attain many different magnifications with your telescope. The telescope comes with two high-quality eyepieces: a 35mm focal length 2" DeepView eyepiece, which provides a magnification of 47x, and a 10mm focal length 1.25" Sirius Plössl eyepiece, which provides a magnification of 165x. Other eyepieces can be used to achieve higher or lower powers. It is quite common for an observer to own five or more eyepieces to access a wide range of magnifications. This allows the observer to choose the best eyepiece to use depending on the object being viewed. At least to begin with, the two supplied eyepieces will suffice nicely.

Whatever you choose to view, always start by inserting your lowest-power (longest focal length) eyepiece to locate and center the object. Low magnification yields a wide field of view, which shows a larger area of sky in the eyepiece. This makes acquiring and centering an object much easier. If you try to find and center objects with high power (narrow field of view), it's like trying to find a needle in a haystack! Once you've centered the object in the eyepiece, you can switch to higher magnification (shorter focal length eyepiece), if you wish. This is especially recommended for small and bright objects like planets and double stars. The Moon also takes higher magnifications well.

---

Deep sky objects, however, typically look better at medium or low magnifications. This is because many of them are quite faint, yet have some extent (apparent width). Deep sky objects will often disappear at higher magnifications, since greater magnification inherently yields dimmer images. This is not the case for all deep sky objects, however. Many galaxies are quite small, yet are somewhat bright, so higher power may show more detail.

The best rule of thumb with eyepiece selection is to start with a low power, wide field, and then work your way up in magnification. If the object looks better, try an even higher magnification. If the object looks worse, then back off the magnification a little by using a longer focal length eyepiece.

## **Astronomical Objects**

Now that your telescope is set up and ready to go, one critical decision must be made: what to look at?

### **A. The Moon**

With its rocky and cratered surface, the Moon is one of the most interesting and easy subjects to view with your telescope. The best time to view it is during its partial phases when shadows fall on the craters and canyon walls to give them definition. While the full moon may look like a tempting target, it is not optimal for viewing. The light is too bright and surface definition is low.

Even at partial phases the Moon is very bright. Use of an optional Moon filter helps to dim the glare. It simply threads onto the bottom of the eyepiece. You'll find the Moon filter improves viewing comfort, and helps bring out the subtle features on the lunar surface.

### **B. The Sun**

You can change your nighttime telescope into a daytime Sun viewer by installing an optional solar filter over the front opening of the telescope. The primary attraction is sunspots, which change shape, appearance, and location daily. Sunspots are directly related to magnetic activity in the Sun. Many observers like to make drawings of sunspots to monitor how the Sun is changing from day to day.

**Important Note: Do not look at the Sun with any optical instrument without a professionally made solar filter, or permanent eye damage could result. Also, be sure to cover the finder scope, or better yet, remove it altogether.**

### **C. The Planets**

The planets don't stay put like the stars, so to find them you should refer to Sky Calendar at our website OrionTelescopes.com, or use the IntelliScope Object Locator. Venus, Mars, Jupiter, and Saturn are the brightest objects in the sky after the Sun and the Moon. Your XX14i is capable of showing you these planets in some detail. Other planets may be visible but will likely appear star-like. Because planets are quite small in apparent size, optional higher power eyepieces are recommended and often required for detailed observations. Not all the planets are usually visible at any one time.

*Jupiter:* The largest planet, Jupiter, is a great subject for observation. You can see the disk of the giant planet and

watch the ever-changing positions of its four largest moons: Io, Callisto, Europa, and Ganymede. Higher power eyepieces should bring out the cloud bands on the planet's disk.

*Saturn:* The ringed planet is a breathtaking sight. The tilt angle of the rings varies over a period of many years; sometimes they are seen edge-on, while at other times they are broadside and look like giant "ears" on each side of Saturn's disk. A steady atmosphere (good seeing conditions) is necessary for a good view. Look closely and you may see the Cassini division, a thin, dark gap in the rings. You should also see one or more of Saturn's moons, which look like faint nearby stars. The brightest is the moon Titan.

*Venus:* At its brightest, Venus is the most luminous object in the sky, excluding the Sun and the Moon. It is so bright that sometimes it is visible to the naked eye during full daylight! Ironically, Venus appears as a thin crescent, not a full disk, when at its peak brightness. Because it is so close to the Sun, it never wanders too far from the morning or evening horizon. No surface markings can be seen on Venus, which is always shrouded in dense clouds.

*Mars:* The Red Planet makes a close approach to Earth every two years. Observing Mars is most favorable at these times. You should see a salmon-colored disk with some distinct dark patches, and you may be able to spot a whitish polar ice cap. To see surface detail on Mars, you will need a high power eyepiece and very steady air!

### **D. The Stars**

Stars will appear as tiny points of light. Even powerful telescopes cannot magnify stars to appear as anything more than pinpoints. You can, however, enjoy the different colors of the stars and locate many pretty double and multiple stars. The famous "Double-Double" in the constellation Lyra and the gorgeous two-color double star Albireo in Cygnus are favorites. Defocusing a star slightly can help bring out its color.

### **E. Deep-Sky Objects**

Under dark skies, you can observe a wealth of fascinating deep-sky objects; that is, objects that reside outside of our solar system. These include gaseous nebulas, open and globular star clusters, and a variety of different types of galaxies.

The large aperture of the XX14i is particularly well suited to gathering light, which is critical for observing these faint celestial entities. For deep-sky observing, it is important that you find an observing site well away from light pollution. Take plenty of time to let your eyes adapt to the darkness. As you become more experienced and your observing skills get sharper, you will be able to ferret out more and more subtle details and structure from these fascinating objects.

Beginners are often surprised to discover that the deep sky objects they see in the eyepiece of a telescope are mostly grayish, not colorful like those you see in long-exposure astro-images. The reason is that our eyes are not sensitive to color in faint light. Still, there is something very special about seeing an astronomical object in real time with your own eyes – "live," if not in living color.

---

### Note About Astro-imaging

The SkyQuest XX14i IntelliScope Truss Tube Dobsonian is designed for visual, not imaging, use. The Dobsonian mount is not an equatorial-type mount, and is not motor driven for long exposure astro-imaging. The telescope has also been optically optimized for visual use, since photographic optimization degrades visual performance.

With that in mind, however, it is possible to do some simple astro-imaging with the XX14i. With the use of afocal imaging techniques (where the camera is simply held to the eyepiece to take a picture) and digital cameras, it is possible to capture images of bright objects. Certain imaging accessories, such as the Orion SteadyPix, can help in obtaining images by the afocal method.

## 6. Care and Maintenance

If you give your telescope reasonable care, it will last a lifetime. Store it in a clean, dry, dust-free place, safe from rapid changes in temperature and humidity. Do not store the telescope outdoors, although storage in a garage or shed is okay. The telescope can be stored assembled or disassembled, but be sure to keep the dust covers on the telescope when not in use. We highly recommend storing the optical tube sections in the optional case set for the XX14i. Small components like eyepieces and other accessories should be kept in an optional accessory case.

Your XX14i requires very little mechanical maintenance. The optical tube is steel and has a painted finish that is fairly scratch-resistant. If a scratch does appear on the tube, it will not harm the telescope. Smudges on the tube or base can be wiped off with a soft cloth and household cleaning fluid.

### Cleaning Eyepiece Lenses

Any quality optical lens cleaning tissue and optical lens cleaning fluid specifically designed for multi-coated optics can be used to clean the exposed lenses of your eyepieces or finder scope. Never use regular glass cleaner or cleaning fluid designed for eyeglasses. Before cleaning with fluid and tissue, however, blow any loose particles off the lens with a blower bulb or compressed air. Then apply some cleaning fluid to a tissue, never directly on the optics. Wipe the lens gently in a circular motion, then remove any excess fluid with a fresh lens tissue. Oily fingerprints and smudges may be removed using this method. Use caution; rubbing too hard may scratch the lens. For larger lenses, clean only a small area at a time using a fresh lens tissue on each area. Never reuse cleaning tissues.

### Cleaning Mirrors

You should not have to clean the telescope's mirrors very often; normally once every few years or so. Covering the telescope with the dust covers when it is not in use will prevent dust from accumulating on the mirrors. Improper cleaning can scratch mirror coatings, so the fewer times you have to clean the mirrors, the better. Small specks of dust or debris have virtually no adverse effect on the visual performance of the

telescope. The large primary mirror and the elliptical secondary mirror of your telescope are front surface aluminized and over-coated with hard silicon dioxide, which prevents the aluminum from oxidizing. These coatings normally last through many years of use before requiring re-coating.

To clean the secondary mirror, you will need to remove it from the telescope. Before doing so, remove the upper tube section from the assembled telescope. Hold the secondary mirror stationary while loosening the center Phillips-head screw. Handle the mirror by its edge; avoid touching the mirror surface itself. Once the mirror (still in its holder) is removed from the tube, follow the same procedure described below for cleaning the primary mirror. You do not need to remove the secondary mirror from its holder when cleaning.

To clean the mirrors, you'll need the following:

- A sink or tub big enough to hold the mirror
- Distilled water, 1 gallon
- Squeeze bottle
- A little dishwashing liquid
- 100% isopropyl alcohol (optional)
- Cotton balls
- Soft towel

To clean the primary mirror, you must carefully remove the end ring and mirror support assembly from the telescope. To do this, remove the screws on the side of the tube near the rear end ring. Then remove the collimation screws on the bottom of the mirror cell. This will allow the end ring to be separated from the mirror support structure, which is attached to the mirror itself.

1. Fill a clean sink or tub – not a bath tub but rather a smaller plastic tub or bin – with room-temperature water, a few drops of liquid dishwashing detergent, and if possible a capful of 100% isopropyl alcohol.
2. With the mirror still in its support cell but with the rear end ring removed, grasp the mirror cell and hold the mirror upside-down. Submerge the aluminized face of the mirror in the solution and gently swish it around for a minute or so.
3. Now remove the mirror from the water and keep it tilted for a few seconds to allow the water to drain off.
4. For the next steps you might want to prop the mirror at a slight angle on your work surface so that water will run off and not collect in the middle.
5. To help dislodge any remaining particulate matter, use a squeeze bottle filled with water to spray a “jet” of water across the mirror surface.
6. Now you're going to use wet cotton balls to clean the mirror. Dump out the solution used in the above steps, rinse the tub, then refill it (or a smaller container, since we won't be immersing the mirror in it this time) with new solution following the same recipe. This will ensure that no particles that came off the mirror in the previous steps

---

are picked up on the cotton balls and rubbed across the mirror in the next steps.

7. Completely submerge a cotton ball in the solution. Starting on one side of the mirror and using extremely light pressure, wipe the cotton ball across the aluminized surface in a straight line. Wipe just once, then discard the cotton ball. Submerge another cotton ball and wipe it across the mirror in a straight line right next to the first wipe, then discard this cotton ball.
8. Repeat this procedure using wet, clean cotton balls for each swipe until you'd cleaned the entire surface of the mirror.
9. Now rinse the aluminized surface of the mirror with room temperature distilled water; a gallon should suffice.
10. Let the mirror air dry in a warm place. Water will run off a clean surface, so keep the mirror slightly tilted while drying. You can remove any random drops of water with the corner of a paper towel. When it is completely dry your mirror should be clean and spot free, and ready to re-install in the telescope.



---

## 7. Specifications

### Optical Tube Assembly (OTA)

Primary mirror:	356mm (14.0") diameter reflective surface, low thermal expansion optical glass, parabolic, center marked
Focal length:	1650mm
Focal ratio:	f/4.6
Secondary mirror:	80mm minor axis, low thermal expansion optical glass
Secondary mirror holder:	4-vane spider assembly, 0.7mm thick spider vanes, 3 SHCS for tilt adjustment
Mirror coatings:	Enhanced reflectivity (94%) aluminum with SiO <sub>2</sub> overcoat
Focuser:	Dual speed Crayford, 11:1 fine focus knob, accepts 2" and 1.25" eyepieces, all metal construction
Optical tube design:	Truss tube
Truss poles:	8 total (4 truss pole assemblies with 2 poles each), 1.0" outer diameter, aluminum black anodized, captive assembly hardware
Navigation knob:	Included
Optical tube material:	Rolled steel, 1.0mm thick
Tube outer diameter:	412mm (16.2")
OTA weight, assembled:	65.8 lbs.
OTA weight, disassembled:	Lower tube section, 36.3 lbs. Upper tube section, 9.4 lbs. Truss pole assemblies, 6.9 lbs. Counterweights (6), 13.2 lbs.
OTA length, assembled:	61"
OTA length, disassembled:	Lower tube section, 21.75" long; Upper tube section, 8.1" long; Truss pole assemblies, 33.75" long

### Mount

Dobsonian base:	Collapsible design, CorrectTension altitude tensioning, side brace supports, carry handle
Azimuth bearing material:	Virgin PTFE/UHMW on Ebony Star laminate
Altitude bearing material:	Ultra-high molecular weight (UHMW) polyethylene on ABS plastic
Altitude bearing diameter:	8.0"
IntelliScope functionality:	Computerized Object Locator system included, 14,000+ object database
Base weight:	45 lbs., assembled
Approximate base dimensions:	29" diameter x 27" tall
<b>Accessories</b>	
2" Eyepiece:	35mm Deep View, 2", multi-coated, threaded for Orion filters
1.25" Eyepiece:	10mm Sirius Plössl, 1.25", multi-coated, threaded for Orion filters
Eyepiece magnifications:	47.1x and 165x
Finder scope:	9x power, 50mm aperture, achromatic, crosshairs, 5° field of view
Finder scope bracket:	Spring-loaded X-Y adjustment, dovetail base
Eyepiece rack:	Holds three 1.25" eyepieces and one 2" eyepiece
Cooling accelerator fan (set of three):	Optional (#7818)





---

## **One-Year Limited Warranty**

This Orion product is warranted against defects in materials or workmanship for a period of one year from the date of purchase. This warranty is for the benefit of the original retail purchaser only. During this warranty period Orion Telescopes & Binoculars will repair or replace, at Orion's option, any warranted instrument that proves to be defective, provided it is returned postage paid. Proof of purchase (such as a copy of the original receipt) is required. This warranty is only valid in the country of purchase.

This warranty does not apply if, in Orion's judgment, the instrument has been abused, mishandled, or modified, nor does it apply to normal wear and tear. This warranty gives you specific legal rights. It is not intended to remove or restrict your other legal rights under applicable local consumer law; your state or national statutory consumer rights governing the sale of consumer goods remain fully applicable.

For further warranty information, please visit [www.OrionTelescopes.com/warranty](http://www.OrionTelescopes.com/warranty).

Orion Telescopes & Binoculars  
Corporate Offices: 89 Hangar Way, Watsonville CA 95076 - USA  
Customer Support: [www.OrionTelescopes.com/contactus](http://www.OrionTelescopes.com/contactus)

© Copyright 2014 Orion Telescopes & Binoculars