

Orion AccuFocus™ Electronic Focuser

#7395

The AccuFocus Electronic Focuser makes achieving a sharp focus much easier, as no vibrations are imparted to the telescope when the focusing shaft is rotated. Focusing, especially at high magnifications, becomes simple and more precise. In fact, you may even see image detail you have never seen before due to “shaky” focusing by hand!

The AccuFocus fits most Orion refractors and reflectors. It also fits several of the focusers Orion sells separately.

Parts List

Refer to Figure 1.

Qty	Description
1	Control box
1	Motor assembly (with shaft coupler for Crayford focuser attached)
1	Cable
1	Shaft coupler for rack-and-pinion focuser
1	Focuser bracket for rack-and-pinion focuser
1	Focuser bracket for Crayford focuser
2	Thumb screws
2	Washers
4	Phillips head screws
2	Hex keys
1	Nylon “hook and loop” adhesive strip

Installation for Crayford Focusers

If you have an Orion Crayford focuser, follow these simple steps to install the AccuFocus. In addition to the provided hex keys, you will need a Phillips head screwdriver.

1. Remove the focus knob from the right-hand side of the focuser. This is done by loosening the set screw that connects the knob to the focusing shaft (Figure 2). Use the supplied 1.5mm hex key to do this. After the set screw is loosened, simply pull the knob off of the focusing shaft.
2. Remove the focuser’s locking thumb screw. This is the chrome, knurled thumb screw that locks the focuser drawtube in place (see Figure 2).
3. Position the focuser horizontally, as shown in Figure 3.
4. Remove the four Phillips head screws from the focusing shaft cover plate. Use your thumb to maintain downward pressure on the cover plate so it does not fall off when the screws are removed (Figure 3). If the focuser drawtube rotates, that is OK.

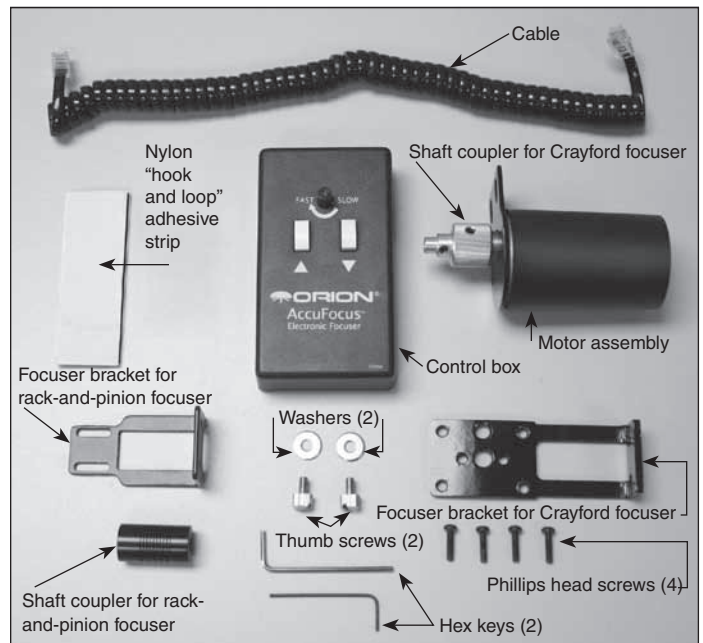

Figure 1. The parts included with the AccuFocus.

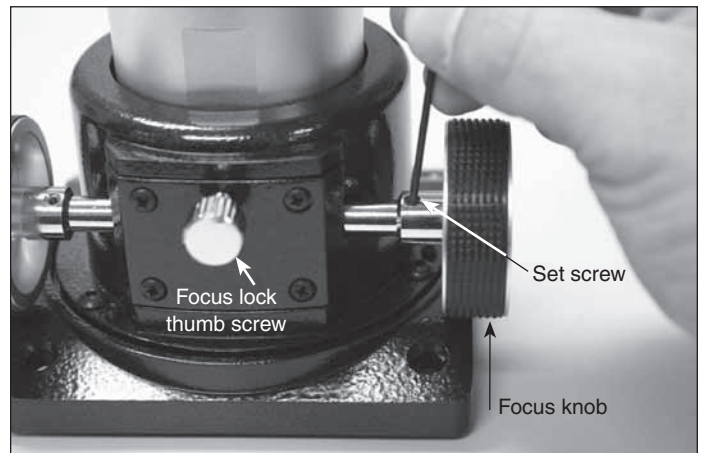

Figure 2. To remove the focus knob from the focusing shaft, first loosen the set screw on the knob’s stem.

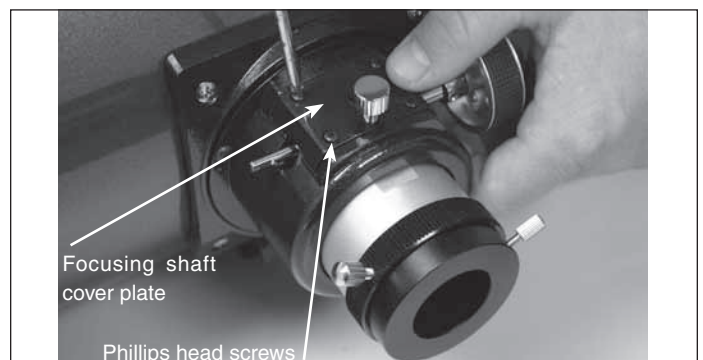

Figure 3. When removing the Phillips head screws, use your thumb to apply downward pressure on the focusing shaft cover plate; this prevents the cover plate (and focusing shaft) from falling off the focuser.

You can reposition the drawtube later, once the focuser bracket is connected.

5. Place the focuser bracket on top of the focusing shaft cover plate. The holes in the bracket should line up with the holes in the cover plate (Figure 4).
6. Use the supplied four Phillips head screws to connect the bracket to the focuser. The screws go through the bracket and the focusing shaft cover plate, and thread into the focuser. Do not firmly tighten the screws yet.
7. If the focuser drawtube has rotated, rotate it back into position now. The flat area on the drawtube should make a good connection with the focusing shaft (see Figure 4).
8. Now, firmly tighten the four Phillips head screws.
9. Replace the focuser's locking thumb screw. Do not tighten the thumb screw.
10. Position the motor so the end of its shaft coupler goes over the exposed end of the focusing shaft.
11. Insert the supplied thumb screws, with washers attached, through the slots in the motor's bracket and thread them into the focuser bracket (Figure 5). You may need to rotate the motor to do this. Tighten the thumb screws firmly with your fingers; you can also use a flat head screwdriver to tighten the thumb screws.
12. Engage the motor drive to the focusing shaft by tightening the set screw on the smaller end of the shaft coupler. Use the provided 2mm hex key to do this. For the most secure connection, make sure the coupler's set screw seats onto the flat area of the focusing shaft. Use the set screw from the focus knob on the opposite end of the focusing shaft as a guide to determine rotationally where the flat on the shaft is (Figure 6).

Note: Do not turn the focus knob manually when the motor drive is engaged, or damage to the motor may result. Be sure to loosen the set screw on the smaller end of the shaft coupler before attempting to manually focus with the focus knob.

Installation for Rack-and-Pinion Focusers

If your telescope has an Orion rack-and-pinion focuser, follow these simple steps to install the AccuFocus. In addition to the provided hex keys, you will need a Phillips head screwdriver.

1. Remove one of the focus knobs from the focuser. This is done by removing the knob's central Phillips-head screw, and then pulling the knob off the focusing shaft. It may take a bit of force to pull the knob off, as there is a glue bond that must be broken.
2. Remove the shaft coupler that comes installed on the motor assembly. This is done by loosening the set screw on the knurled section of the coupler and then pulling the coupler off the motor's shaft with a twisting motion.
3. Connect the black flexible shaft coupler to the motor's shaft. The end of the coupler with the smaller opening goes onto the shaft. First, loosen the set screw and place the coupler on the motor's shaft. Then, rotate the coupler until the set screw

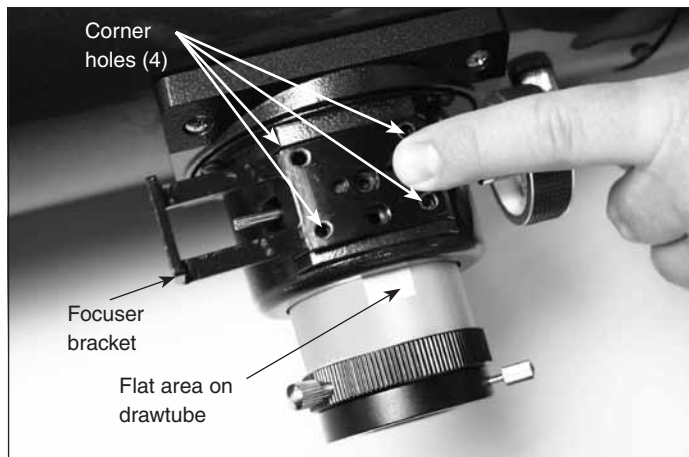

Figure 4. The bracket goes over the cover plate so the four corner holes line up with each other.

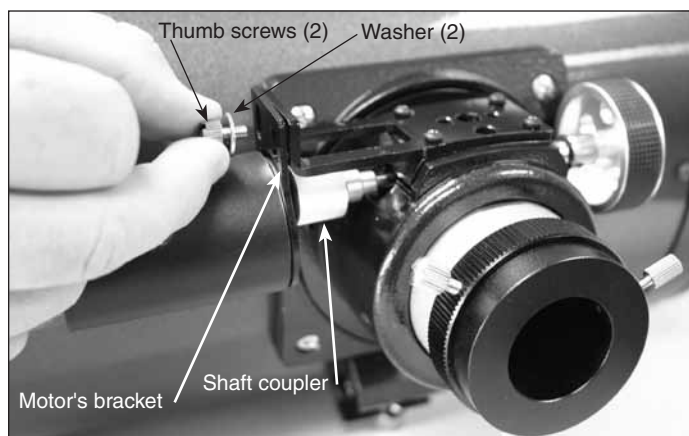

Figure 5. The two supplied thumb screws (with washers attached) connect the motor's bracket to the focuser bracket.

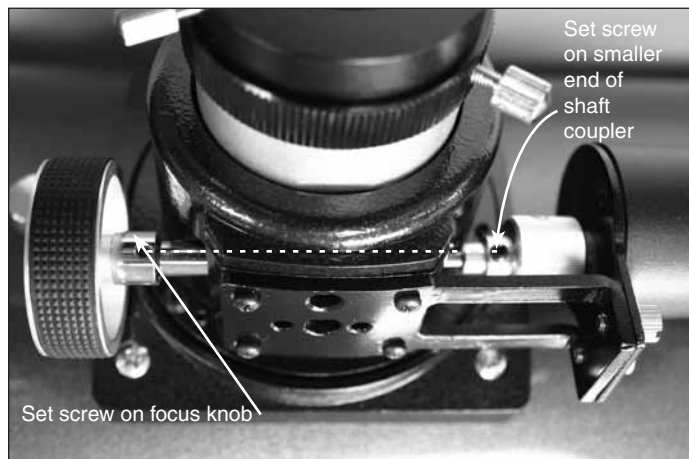

Figure 6. When the manual focus knob is rotated so the set screw on its stem is rotationally aligned with the set screw on the motor's shaft coupler, the flat area of the focusing shaft is directly under the set screw on the shaft coupler. Tightening the set screw onto the flat section of the shaft insures best motor engagement.

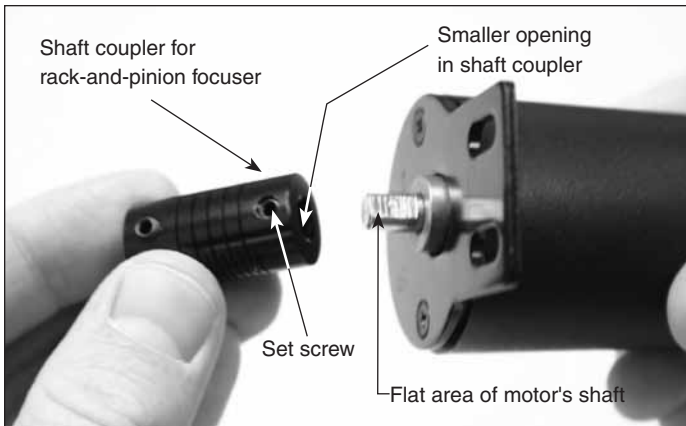

Figure 7. The end of the shaft coupler with the smaller opening goes over the motor's shaft. Register the set screw with the flat area of the motor's shaft, and tighten the set screw with the 2mm hex key.

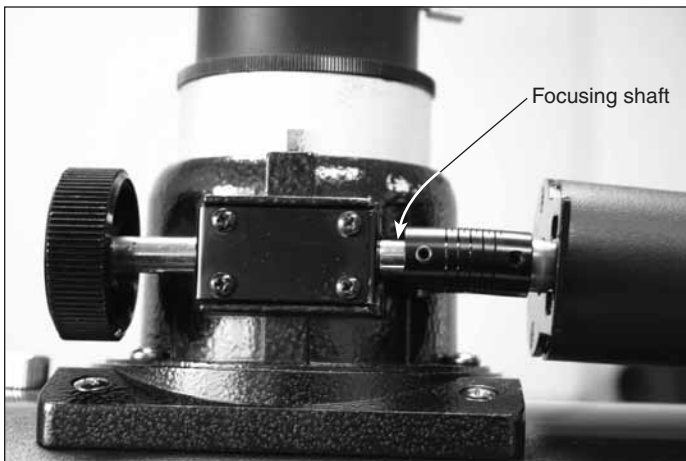

Figure 8. Push the shaft coupler, with motor attached, onto the exposed end of the focusing shaft. Make sure the coupler goes as far as it can go onto the shaft.

is directly over the flat area of the motor's shaft, and firmly tighten the set screw with the 2mm hex key (Figure 7).

4. Use the 2mm hex key to loosen both set screws on the opposite end of the flexible shaft coupler.
5. Push the shaft coupler, with motor attached, onto the focusing shaft. Make sure the coupler goes as far as it can go onto the shaft (Figure 8).
6. Attach the focuser bracket to the pinion gear cover. This is done by removing two of the four Phillips head screws that secure the pinion gear cover to the focuser (Figure 9). Remove the two screws located on the same side of the focuser as the motor. Now, orient the bracket as shown in Figure 9, and replace the two screws through the focuser bracket and pinion gear cover. Do not completely tighten the screws yet.
7. Slide the focuser bracket forward and back in its slots until the two holes in the bracket's end are flush against the two holes in the motor's bracket (refer to Figure 10). You may need to rotate the motor assembly to have the holes line up.

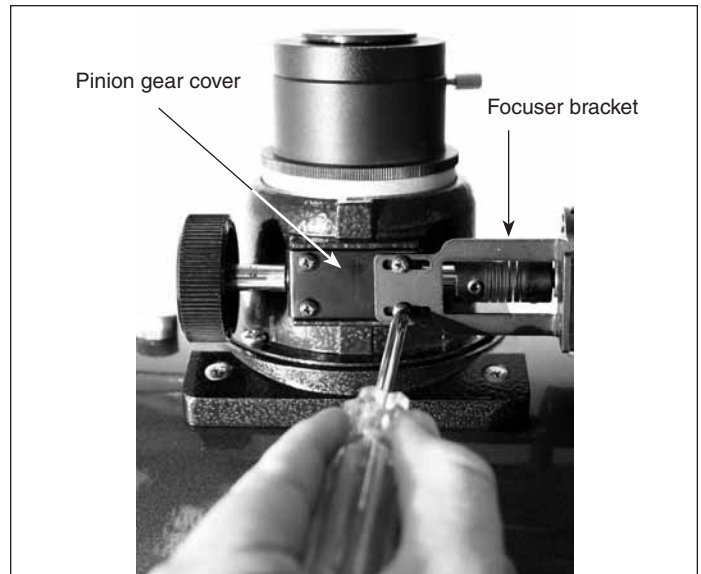

Figure 9. The focuser bracket is connected with two of the four pinion gear cover screws.

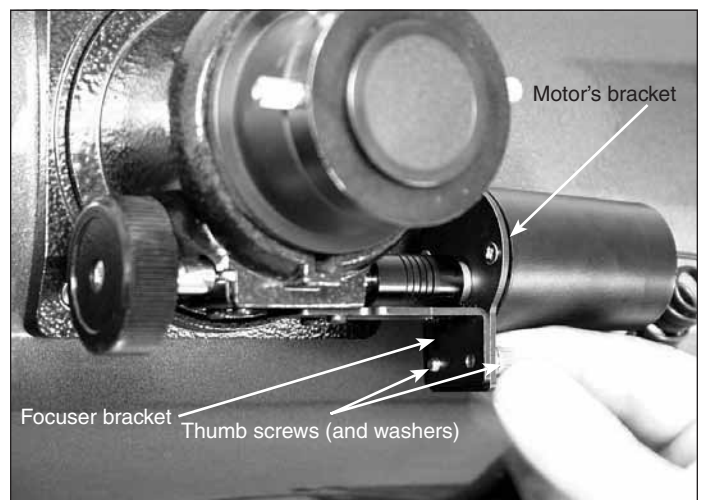

Figure 10. Connect the motor's bracket to the focuser bracket with the two thumb screws (and washers). The brackets should be flush against each other.

8. Now, tighten the two pinion gear cover screws that attach the focuser bracket to the focuser (see Figure 9).
9. Insert the thumb screws, with washers attached, through the motor's bracket and thread them into the focuser bracket (Figure 10). Tighten the thumb screws firmly with your fingers; you can also use a flat head screwdriver to tighten the thumb screws.
10. Tighten the two set screws on the end of the shaft coupler that is on the focusing shaft. The motor is now engaged with the focusing shaft.

Note: Do not turn the focus knob manually when the motor drive is engaged, or damage to the motor may result. Be sure to loosen the two set screws which connect the shaft coupler to the focusing shaft before attempting to manually focus with the focus knob.



Figure 11. The assembled and installed AccuFocus Electronic Focuser.

Finishing Assembly

The AccuFocus is now installed on the telescope's focuser. To complete the assembly, plug one end of the cable into the motor, and the other end into the control box. The AccuFocus should appear as in Figure 11.

The AccuFocus requires a standard 9V battery (not included) to operate. The 9V battery goes into the battery compartment in the rear of the control box. To reveal the compartment, slide the battery cover off by first pressing the tab on the cover.

Adhesive "hook and loop" strips are provided for keeping the control box in a convenient location on the telescope. Apply one of the strips to the rear surface of the control box, and the other strip to the telescope where you wish to hang the control box when it's not in use.

Use of the AccuFocus

Using the AccuFocus to focus your telescope's eyepiece is very straightforward and simple. Just push one of the buttons on the control box, and the focuser drawtube will begin moving. Push the other button to move the focuser drawtube in the opposite direction. To increase the speed of the motor, rotate the speed knob clockwise. To decrease the speed, rotate the knob counterclockwise.

Generally, begin focusing with the AccuFocus at a higher speed to get close to focus. Then, slow down the speed as you approach the actual focus point to get the most precise focus. Keep in mind that best focus will be achieved by focusing on a bright star.

Remember, if you wish to manually focus with the focus knob, be sure to first disengage the AccuFocus. This is done by loosening the set screw(s) on the shaft coupler that connect it to the focusing shaft. Use the supplied 2mm hex key to loosen the set screw(s).

Troubleshooting

If you are having problems with your AccuFocus, one of these tips may help.

1. For rack-and-pinion focusers, make sure the four pinion gear cover screws (Figure 9) are not too tight. They should be snug, but if too tight they will restrict the motion of the focuser's rack-and-pinion gears.
2. The large thumb screw on the focuser's body will lock the focuser drawtube in place once the telescope is properly

focused. Before focusing with the AccuFocus, remember to first loosen this thumb screw. Do not loosen the thumb screw too much, as some tension helps keep the drawtube secure within the focuser.

3. If you find the drawtube tension when focusing is either too tight (the AccuFocus struggles to turn the focusing shaft) or too loose (the image shifts when focusing or the drawtube does not move), you can adjust it by tightening or loosening the drawtube tensioning set screws on the focuser. These are the small set screws located near the focus lock thumb screw. Orion rack-and-pinion focusers have two of these set screws, while Orion Crayford focusers have either one or two of these set screws. Adjusting these set screws requires a hex key.
4. If the motor shifts on the focuser bracket, tighten the thumb screws that connect the motor's bracket to the focuser bracket more firmly. You can use a flat-head screwdriver to tighten the thumb screws, if necessary. For rack-and-pinion focusers, also make sure the two pinion gear cover screws that attach the focuser bracket are adequately tightened.
5. If the shaft coupler is rotating with the motor, but the focus shaft is not turning, tighten the set screw(s) on the end of the coupler connected to the focusing shaft.
6. If the shaft coupler is not rotating, but you can hear the motor running, try tightening the set screw on the coupler that connects it to the motor's shaft. For Crayford focusers, this is the set screw on the knurled section of the coupler.
7. If the motor begins to slow or no longer provides enough torque to smoothly rotate the focusing shaft, replace the 9V DC battery.

Specifications

Fits: All standard Orion rack & pinion refractors and reflectors except the Observer 60, StarBlast 4.5, and SkyScanner 100. The following Orion refractors and reflectors with Crayford focusers: ED80, 100, 120; EON72, 80, 120 (with dual speed bracket available from Orion); 6" Imaging Newtonian (with dual speed bracket available from Orion); All Orion Newtonian reflector optical tubes 6-10". The complete line of SkyQuest XT, XT_i XX, XT_g, and XX_g of all sizes except XT4.5. Models with dual speed Crayford focusers will require the dual speed bracket available from Orion.

Fastest motor speed: Rotates focusing shaft approximately once every 7 seconds
Slowest motor speed: Rotates focusing shaft approximately once every 28 seconds
Power requirement: 9V DC (not included)

One-Year Limited Warranty

This Orion AccuFocus Electronic Focuser is warranted against defects in materials or workmanship for a period of one year from the date of purchase. This warranty is for the benefit of the original retail purchaser only. During this warranty period Orion Telescopes & Binoculars will repair or replace, at Orion's option, any warranted instrument that proves to be defective, provided it is returned postage paid to: Orion Warranty Repair, 89 Hangar Way, Watsonville, CA 95076. If the product is not registered, proof of purchase (such as a copy of the original invoice) is required.

This warranty does not apply if, in Orion's judgment, the instrument has been abused, mishandled, or modified, nor does it apply to normal wear and tear. This warranty gives you specific legal rights, and you may also have other rights, which vary from state to state. For further warranty service information, contact: Customer Service Department, Orion Telescopes & Binoculars, 89 Hangar Way, Watsonville, CA 95076; (800)-676-1343.