

# Instruction Manual **omegon**

## Omegon® LRF 600 rangefinder

*Congratulations on the purchase of the new Omegon® LRF 600 rangefinder. The Omegon® LRF 600 rangefinder is used for measuring distances from 5 up to 600 metres using an invisible laser beam.*



### 1. Included Accessories

Pulse strap and soft pouch. Battery is NOT included.

### 2. Getting Started

Take some time to identify the product's parts.

- 1- Eyepiece;
- 2- Strap slit;
- 3- Battery cap/Battery compartment (1x CR2 Battery);
- 4- ON push button; Unit selection (metres/yards);
- 5- MODE push button; Measure type selector.

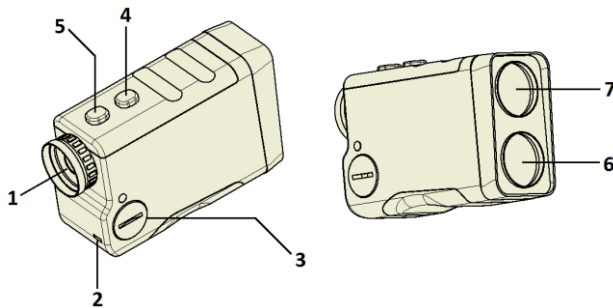

Figure 1.

### 3. How to use the Omegon® LRF 600 rangefinder

#### 3.1. How it works and limitations.

An invisible laser beam (905nm) is pointed to the target being measured. The laser beam is reflected and the travel time indicates the distance between observer and target. The measurement is accurate up to 1 metre. The minimum

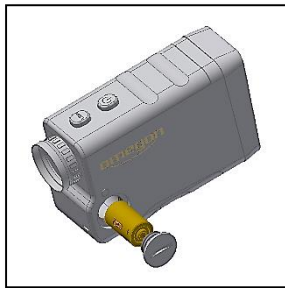

Figure 2.

measuring distance is 5 metres, while the maximum is 600 metres. The target should be able to reflect the laser beam. The darker the target the dimmer is the reflects laser beam, with black being the worst colour a red reflecting surface the best colour. The laser beam angle is also important. The laser beam should be hitting the target at 90 deg. (perpendicular to the laser beam) steep angles provide limited readings. Sunny days interfere with the readings and the beam range, overcast sky allows accurate measurements. Rainy or foggy days reduce the reading range.

#### 3.2. Using the Omegon® LRF 600 rangefinder

Release the threaded battery cap, use a coin to rotate it. Insert the CR2 battery and make sure that the positive side points out. Place the battery cap back and retighten it. Press the ON push button (figure 3) for 2 seconds.



Figure 3. Press ON.

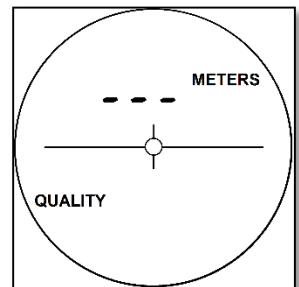

Figure 4. Reticule is visible.



Figure 5. Press mode 1x.

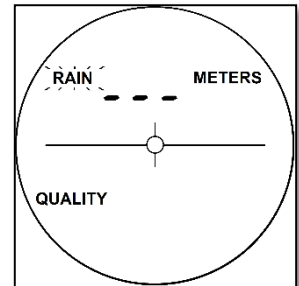

Figure 6. REFL flickers.



Figure 7. Press Mode 2x

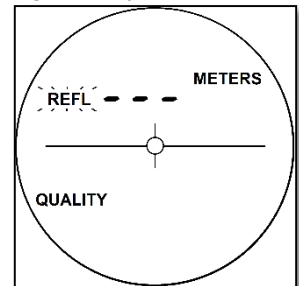

Figure 8. RAIN flickers.



Figure 9. Press MODE 3x.

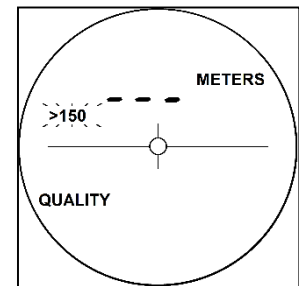

Figure 10. >150 flickers.



Figure 12. Quality of beam.

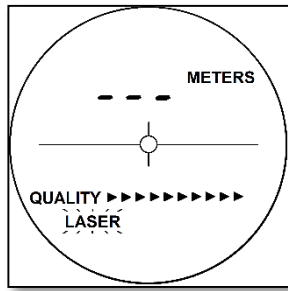

Figure 13. Quality measure.

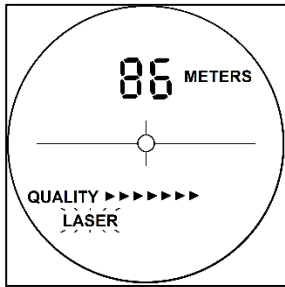

Figure 14. Distance measured.

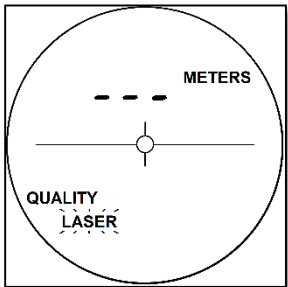

Figure 15. Quality measure.

### 3.3. Settings for observing conditions.

Push the MODE button once to change settings to RAIN (figure 5). This should be used when it is raining or if the air is humid (foggy) and for distances more than 60m. Pressing twice the MODE button allows to change to REFL (figure 7). This should be used when a target is too reflective and scatters the laser beam. Finally pressing the MODE button once more chooses >150 (figure 9). This is used to measure objects that are partially covered by trees, power cables or other, target must be at distance more than 150m. The ">150" sign flickers.

### 3.4. Measuring the distance.

Once the right observing conditions mode is selected (3.3) you can start measuring distances. Press ON button continuously to measure until LASER flickers (figure 12) and a distance is measured and shown in the display (figure 13). The reflected laser beam can be measured even if the reflecting conditions are far from ideal. The quality of this reflection is shown above

the flickering LASER. Excellent reflection quality is up to 10 black triangle marks. Moderate reflection is from 4 to 8. Mediocre is below 3.

If "\_\_\_" is shown there is no laser beam reflection, the target is too far away or too close (figure 15).

### 4. Features

Dimensions: 40x105x75mm;

Weight: 180g;

Power: 1x CR2 Battery DC 3v;

Laser beam: 905nm;

Laser peak output: 33W max;

Power: 6x;

Lens: 25mm diameter;

Eyerelief: 12mm;

Exit pupil: 3.8mm;

Field of view (FOV) 122m @1000m;

Accuracy: less than 1 meter.

**Although the laser radiation at 905nm is not focused by the human eye we do NOT recommend to point it to someone's surface.**

Annotations:

**Do not press MODE and ON button at the same time!**

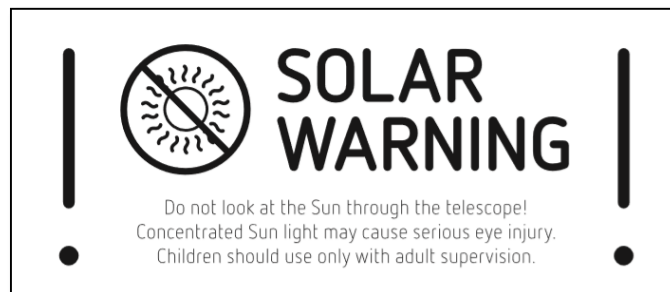

Questions? Visit our website [www.astroshop.eu](http://www.astroshop.eu) and drop us a line\* nimax Gmbh Otto-Lilienthal-Str. 9 D-86899 Landsberg am Lech